



CVS575

Voltage Controlled SAW Oscillator

3.3V LVPECL

5×7.5mm SMD

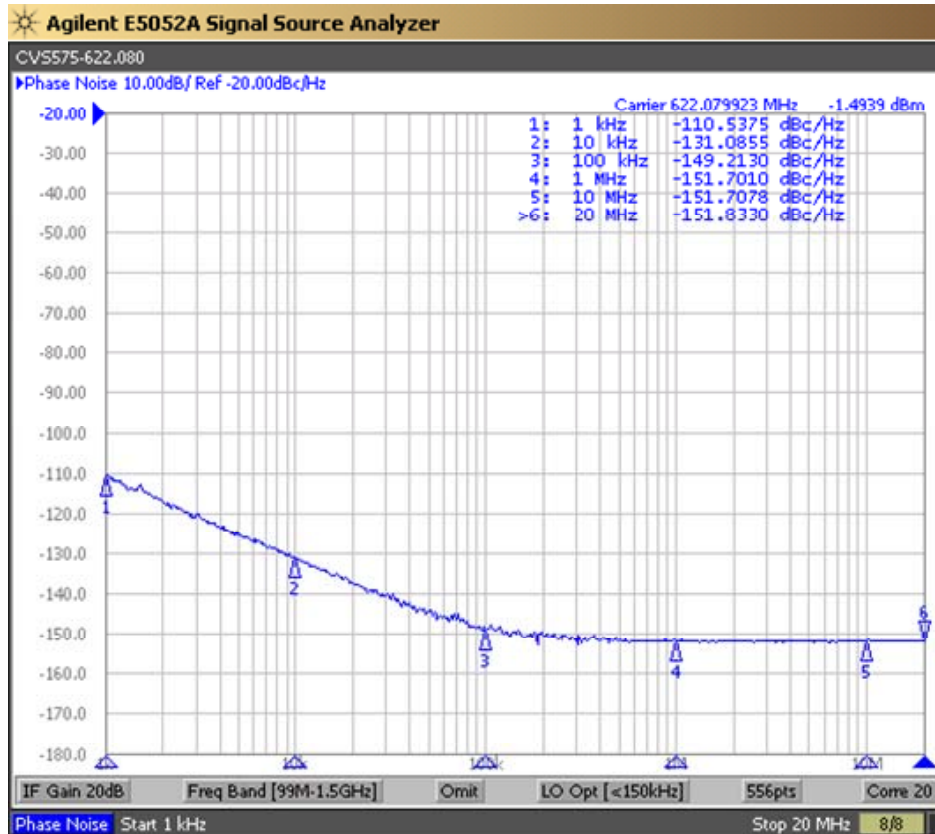

Model CVS575 is a SAW(surface acoustic wave) based Voltage Controlled Oscillator (VCISO) designed for High Performance PLLs. It is an ideal choice for Telecommunication applications needing to meet Low Jitter generation requirements.

It is housed in the industry standard 5×7.5×2.5mm SMD package. The Enable/Disable function was designed to be used with CMOS logic levels for ease of interfacing. It is not necessary to convert to LVPECL logic to turn the Output ON and OFF.

Rev: P
Date: 02-Oct-2017
Page 1 of 2

CVS575

Voltage Controlled SAW Oscillator

3.3V LVPECL

5×7.5mm SMD



Performance Specification	MIN	TYP	MAX	UNITS
Nominal Frequency: <i>Customer Specified</i>	315		1000	MHz
Absolute Pulling Range:	±50			ppm
Frequency Stability:		±150		ppm
Linearity:		±15		%
Tuning Sensitivity, Kv:		+275		ppm/V
Output Phase Noise: (622.08 MHz)				
@1kHz Offset		-110		dBc/Hz
@10kHz Offset		-130		dBc/Hz
@100kHz Offset		-149		dBc/Hz
@1MHz Offset		-150		dBc/Hz
@10MHz Offset		-151		dBc/Hz
Jitter: 12kHz-20MHz SONET OC-48 (12kHz~20MHz) SONET OC-192 (50kHz~80MHz)		0.18 0.12		ps, RMS ps, RMS
Rise/Fall Times, tr/tf 20-80%	100		240	ps
Output High Voltage, V _{OH}	2.215		2.420	V
Output Low Voltage, V _{OL}	1.470		1.745	V
Enable High Voltage, V _{IH}	2.0		V _{CC}	V
Disable Low Voltage, V _{IL}	GND		0.8	V
Enable High Current, I _{IH}			+150	uA
Disable Low Current, I _{IL}			-150	uA
Duty Cycle:	45	50	55	%
Supply Voltage:	3.0	3.3	3.6	V
Supply Current, I _{CC} :		82		mA
Control Voltage:	0		3.3	V
Input Impedance:		100		kΩ
Input Modulation:		500		kHz
Operating Temperature:	0		+70	°C
Storage Temperature:	-45		+90	°C

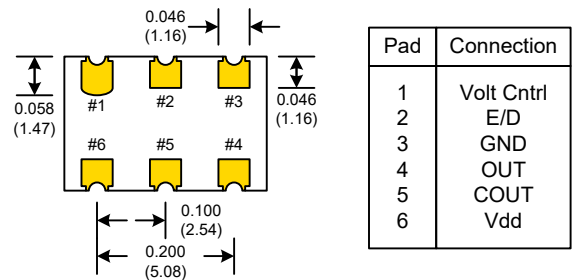
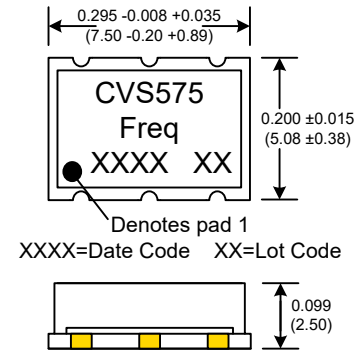

PAD FINISH: Immersion Gold (ENIG); 5 micro inches maximum

SUGGESTED PAD LAYOUT

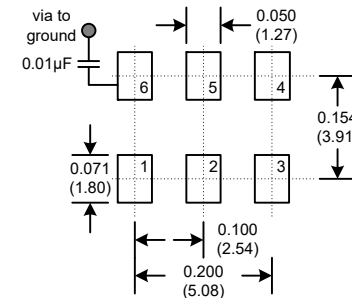

RECOMMENDED REFLOW SOLDERING PROFILE

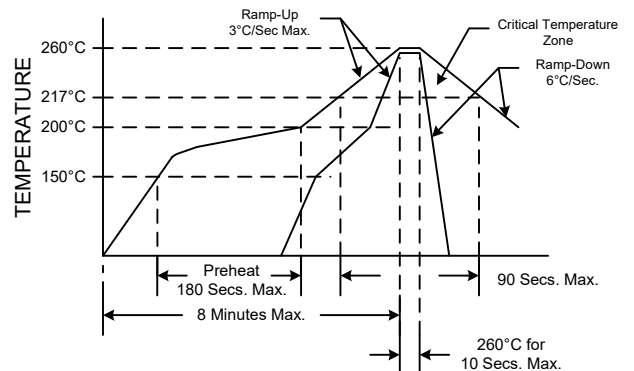

NOTE: Reflow Profile with 240°C peak also acceptable.

Parameter	Conditions
Mechanical Shock	MIL-STD-883, Method 2002
Mechanical Vibration	MIL-STD-883, Method 2007
Solderability	MIL-STD-883, Method 2003
Resistance to Solvents	MIL-STD-883, Method 2015

Rev: P
Date: 02-Oct-2017
Page 2 of 2