



Quartz Crystal

SMD-version

model	KX - C
frequency range	3,50 ~ 24,0 MHz
mode	fundamental, 3 rd overtone upon request
operating temperature	standard -20° ~ + 70°C available -40° ~ + 85°C (=KX-CT) available -40° ~ +105°C (=KX-CE)
frequency tolerance at +25°C	± 50 ppm
temperature tolerance at -20° ~ + 70°C -40° ~ + 85°C -40° ~ +105°C	± 50 ppm ± 100 ppm ± 120 ppm
load capacitance C _L	standard: 16 pF, avail. 12 ~ 20 pF
series resonance R1 max.	3,5 ~ 3,9 MHz 150 Ohm 4,0 ~ 5,99 MHz 120 Ohm 6,0 ~ 7,99 MHz 80 Ohm 8,0 ~ 9,99 MHz 60 Ohm > 10,0 MHz 50 Ohm
aging at +25°C (first year) max.	± 5 ppm
shunt capacitance C _O max.	7,0 pF
drive level max.	0,1 mW
contents of reel	1000 pcs.
part no.	12.xxxxx

Dimensions (mm):

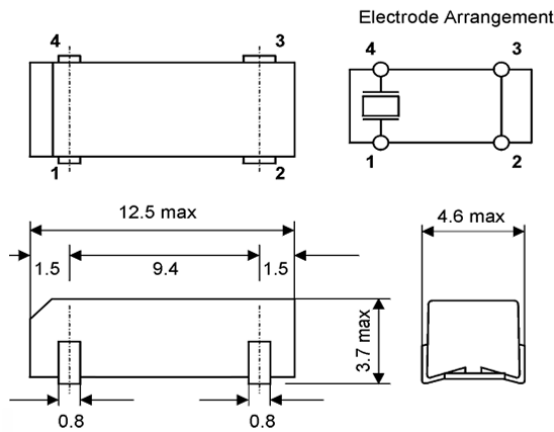

Reflow soldering condition:

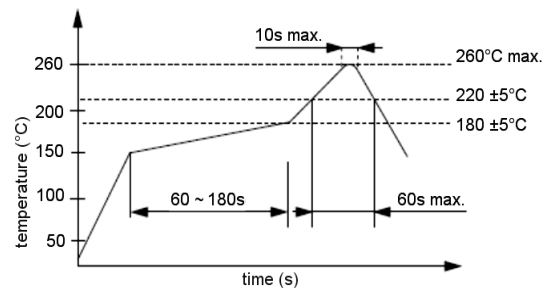

Tape specification:

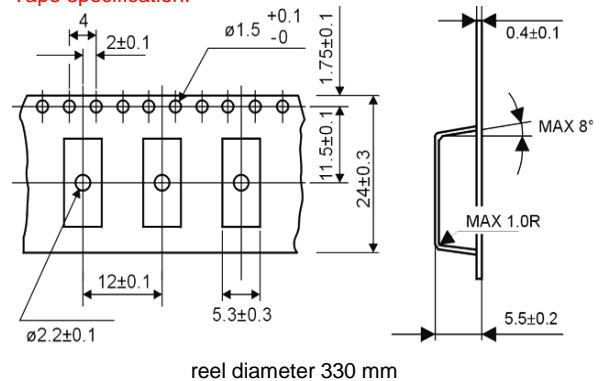

Suggested soldering pad:

