

PAD	CONNECTION
1	Crystal
2	Ground & lid
3	Crystal
4	Ground & lid

Features

- ▶ Fundamental mode up to 315MHz
- ▶ Plasma etched inverted mesa process
- ▶ Wide pulling range (fundamental mode)
- ▶ Small & medium volumes also available
- ▶ Custom frequencies available on short lead times

Specifications

Parameters	Product	Option Codes	
	GSX-228		
Frequency range:	20.0 ~ 315MHz	■	
Calibration tolerance:	±10ppm ±20ppm ±30ppm Other values	□ □ ■ □	1 2 3 specify
Temperature stability:	±10ppm ±20ppm ±30ppm ±50ppm Other values	□ □ ■ □ □	1 2 3 5 specify
Operating temperature range:	-20 to +70°C -40 to +85°C Other values	■ □ □	2 4 specify
Storage temperature range:	-40 to +90°C	■	
Circuit condition:	8pF 9pF 12pF 16pF 20pF Series resonant Other values	■ □ □ □ □ □ □	M N B D F S specify
Oscillation mode:	Fundamental	■	F
Equivalent series resistance (max):	100Ω (20.0 ~ 35.9MHz) 80Ω (36.0 ~ 69.9MHz) 60Ω (70.0 ~ 315MHz, fund)	■ ■ ■	
Ageing:	±3ppm max first year	■	
Test drive level:	10μW typ, 100μW max (<70.0MHz) 2.0μW max (70.0MHz+)	■ ■	
Soldering condition:	260°C, 10sec x2 max	■	

■ Standard. □ Optional - Please specify required code(s) when ordering

Ordering Information

Product name + option codes + frequency

eg: **GSX-228/234DF 12.80MHz** 20/30/40/16-F

GSX-228/352BF 100MHz 30/50/20/12-F

Option code X (eg GSX-228/X) denotes a custom specification.

◆ ±10ppm calibration and/or temperature stability may not be available above 70.0MHz. Please check before ordering.

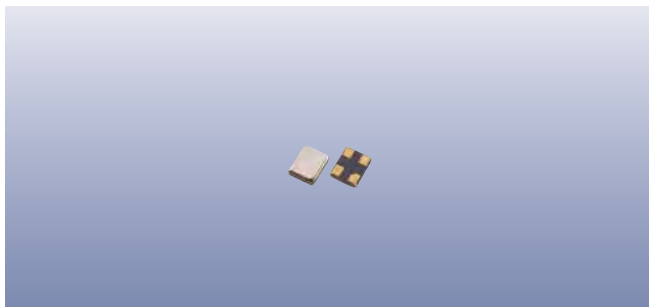

Construction

- ▣ Ceramic body with gold-plated pads
- ▣ Metal lid, seam sealed

Composition



This product is lead-free, and is fully compliant with the RoHS 2 directive 2011/65/EC



LeadFree

Packaging & Handling

Production quantities supplied on T&R, 3k pcs per reel.
Small quantities may be supplied on tape (no reel), or in bulk.

Marking

FREQUENCY
DC

Marking type: Laser
DC = Date code in YM, eg "EB" = Feb 2015

	A	B	C	D	E	F	G	H	J	K	L	M
Y	1	2	3	4	5	6	7	8	9	0		
M	Jan	Feb	Mar	Apr	May	Jun	Jul	Aug	Sep	Oct	Nov	Dec

Tape & Reel Specification

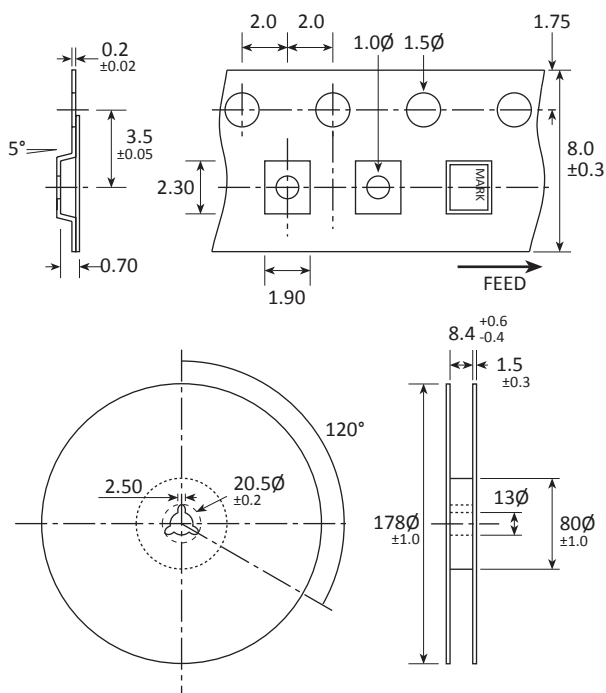

Not to scale. Dimensional tolerances ±0.1mm unless otherwise stated.

Soldering Profile

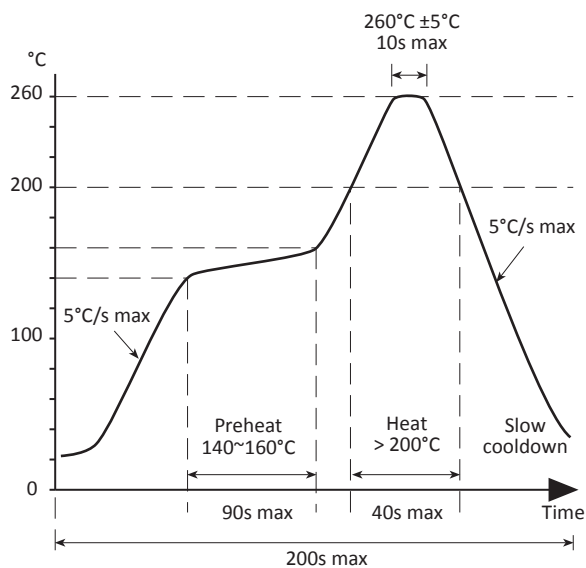

Maximum solder resistance: 260°C x 10 secs x 2.