

FEATURES	APPLICATIONS
<ul style="list-style-type: none"> ±20ppm (Frequency Stability) Available Ceramic Package LVDS RoHS Compliant Programmed Oscillator Tape and Reel 	<ul style="list-style-type: none"> Micro Processors FPGA Storage Area/Networking Digital Video SONET/SDH



PART NUMBERING GUIDE	
<p>SUNTSU QUICK TURN OSC → SOQ 53 L 3 A 48 1 - 100.000M ← FREQUENCY (MHz)</p> <p>5.0 mm x 3.2mm → TRI-STATE (ENABLE/DISABLE)</p> <p>LVDS → 1: Pin 1 2: Pin 2</p> <p>SUPPLY VOLTAGE</p> <p>2: 2.5V±5% 3: 3.3V±5%</p> <p>FREQUENCY STABILITY</p> <p>A: ±50ppm B: ±30ppm C: ±25ppm *D: ±20ppm</p> <p>OPERATING TEMPERATURE RANGE</p> <p>07: 0°C to +70°C 16: -10°C to +60°C 17: -10°C to +70°C 27: -20°C to +70°C 38: -30°C to +85°C 48: -40°C to +85°C</p>	<p>Cage Code: 4GUT4</p> <p>To customize your parameters contact a Suntsu representative.</p> <p>* For frequency stability option D contact a Suntsu representative.</p>

ELECTRICAL PARAMETERS		UNITS	MIN.	TYP.	MAX.	REMARKS
Frequency Range		MHz	8		1500	
Frequency Stability (Includes Initial Tolerance at 25°C, Frequency Stability over Operating Temperature, Output Load Change, Supply Voltage Change, and First Year Aging at 25°C.)		ppm	-20		+20	See part numbering guide for options.
Operating Temperature		°C	-40		+85	See part numbering guide for options.
Storage Temperature			-55		+125	
Supply Voltage (V _{DD})	2.5V Option	V	2.375	2.5	2.625	
	3.3V Option		3.135	3.3	3.465	
Current (I _{DD})	2.5V Option	mA			65	
	3.3V Option				70	
Output Load (LVDS)		Ω			100	
Output Logic Levels	Output Logic High (V _{OH})	V		1.43	1.6	
	Output Logic Low (V _{OL})		0.9	1.1		
Differential Output Voltage (V _{OD})		mV	247	330	454	
Differential Output Error (δV _{OD})		mV			50	
Offset Voltage (V _{OS})		V	1.125	1.250	1.375	
Offset Error (δV _{OS})		mV			50	
Rise (T _R) and Fall (T _F) Time		ns			1	
Symmetry (Duty Cycle)		%	45	50	55	
Tri-State Input Voltage	Enable	V	0.7*V _{DD}			No Connection.
	Disable				0.3*V _{DD}	
Start-Up Time		ms			10	
Phase Jitter (12kHz ~ 20MHz)		ps		0.7	1.5	

OUTLINE DRAWING															
	<p>RECOMMENDED LAND PATTERN</p>														
<p>NOTE: Dimensions in millimeters (mm).</p>	<table border="1"> <thead> <tr> <th>PIN</th> <th>FUNCTION</th> </tr> </thead> <tbody> <tr> <td>1</td> <td>TRI-STATE or NC</td> </tr> <tr> <td>2</td> <td>TRI-STATE or NC</td> </tr> <tr> <td>3</td> <td>GND</td> </tr> <tr> <td>4</td> <td>OUTPUT</td> </tr> <tr> <td>5</td> <td>COMP OUTPUT</td> </tr> <tr> <td>6</td> <td>V_{DD}</td> </tr> </tbody> </table>	PIN	FUNCTION	1	TRI-STATE or NC	2	TRI-STATE or NC	3	GND	4	OUTPUT	5	COMP OUTPUT	6	V _{DD}
PIN	FUNCTION														
1	TRI-STATE or NC														
2	TRI-STATE or NC														
3	GND														
4	OUTPUT														
5	COMP OUTPUT														
6	V _{DD}														

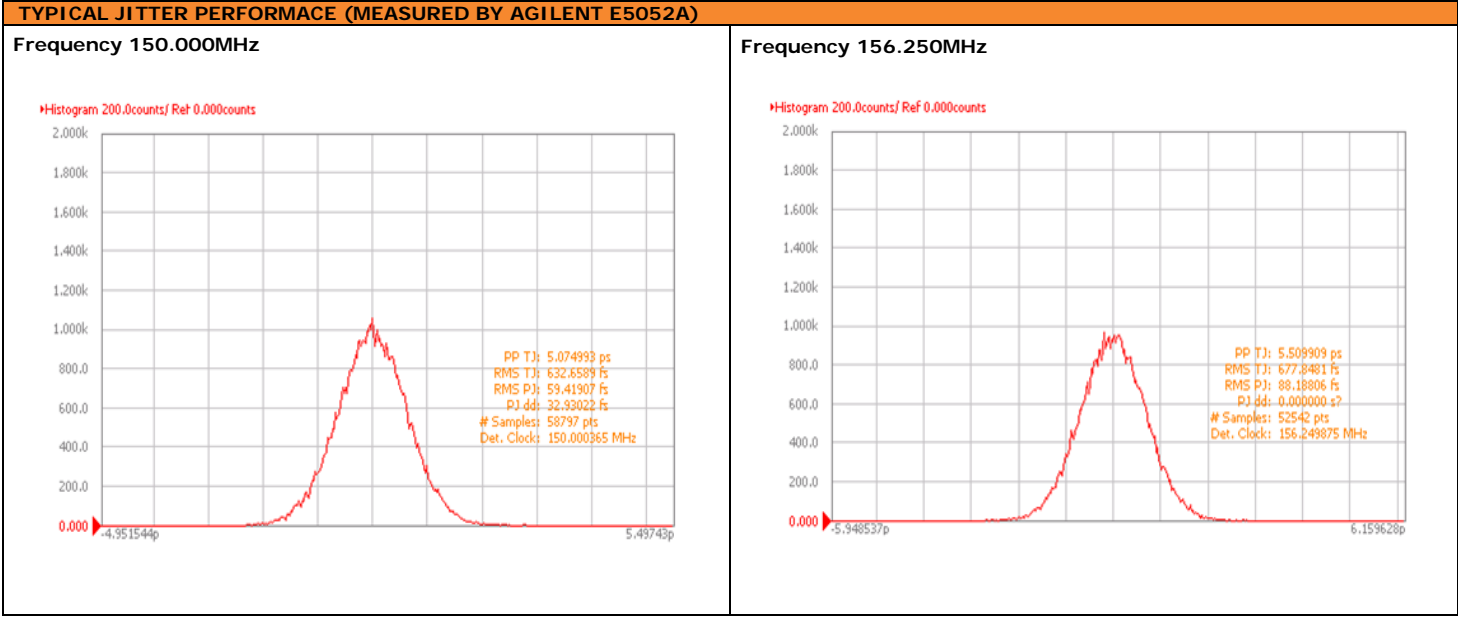
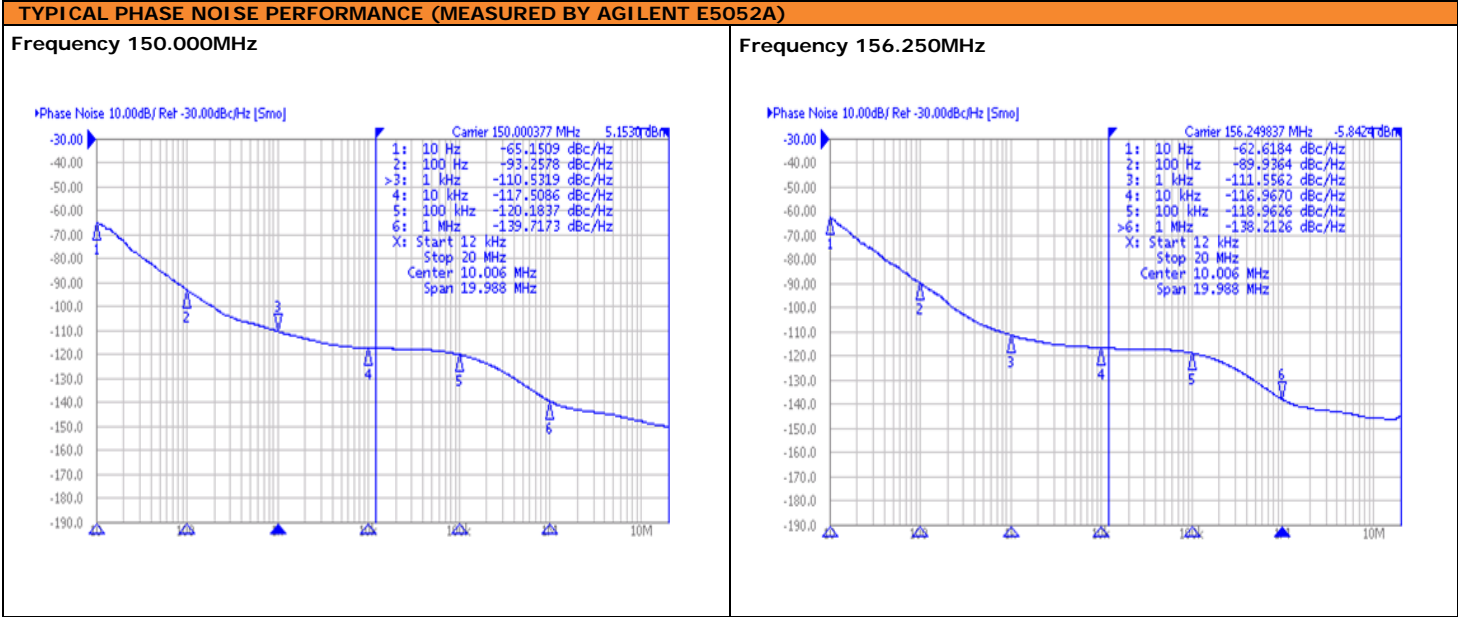
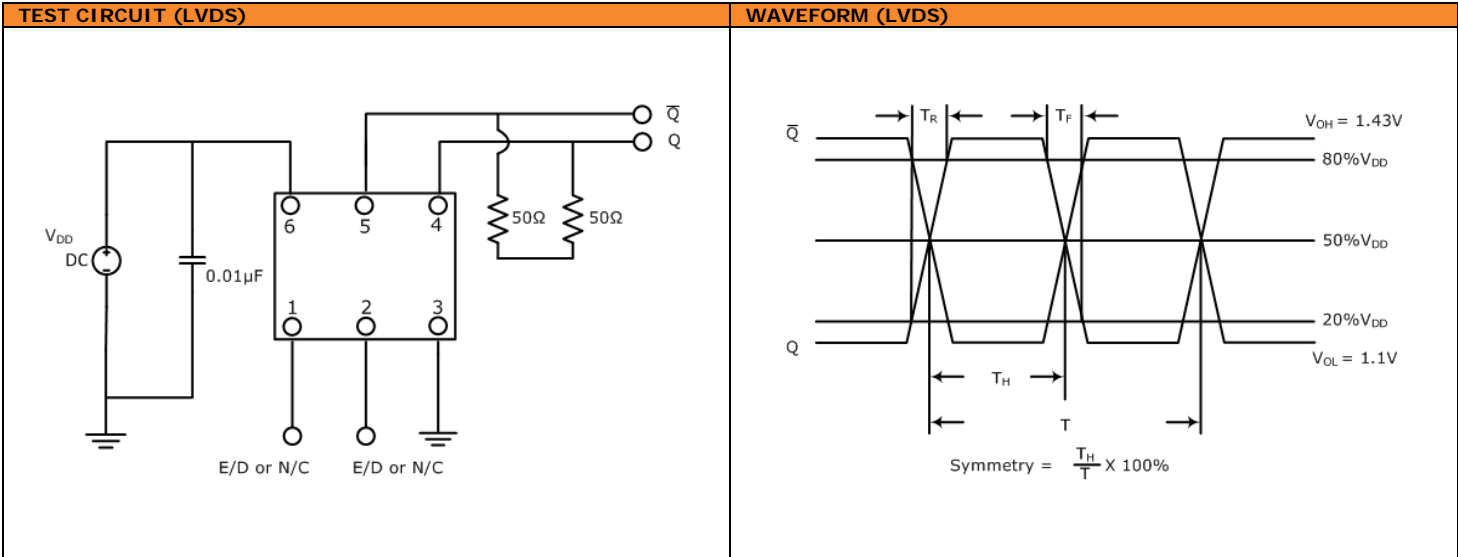

ENVIRONMENTAL & MECHANICAL SPECIFICATIONS

Temperature Cycling	MIL-STD-883, Method 1010, Condition B
Fine Leak Test	MIL-STD-883, Method 1014, Condition A
Gross Leak Test	MIL-STD-883, Method 1014, Condition C
Mechanical Shock	MIL-STD-883, Method 2002, Condition B
Vibration	MIL-STD-883, Method 2007, Condition A
Moisture Resistance	MIL-STD-883, Method 1004
Moisture Sensitivity	J-STD-020, MSL 1
Resistance to Soldering Heat	MIL-STD-202, Method 210, Condition K
Resistance to Solvents	MIL-STD-202, Method 215
Solderability	MIL-STD-883, Method 2003

REFLOW PROFILE

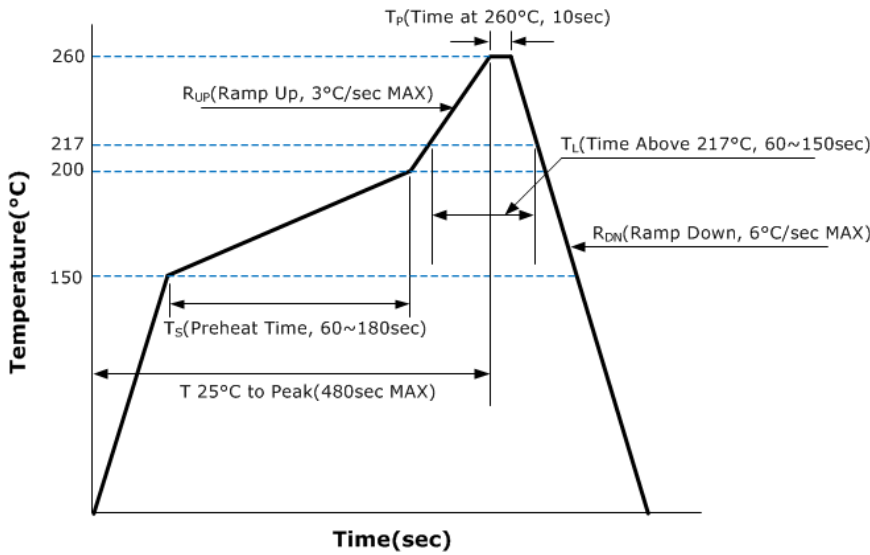

MARKING

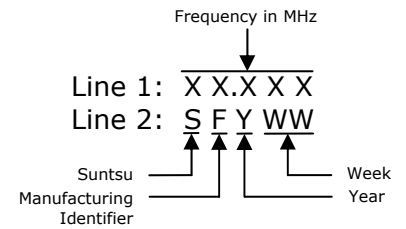

TAPE AND REEL DIMENSIONS

1,000pcs/reel

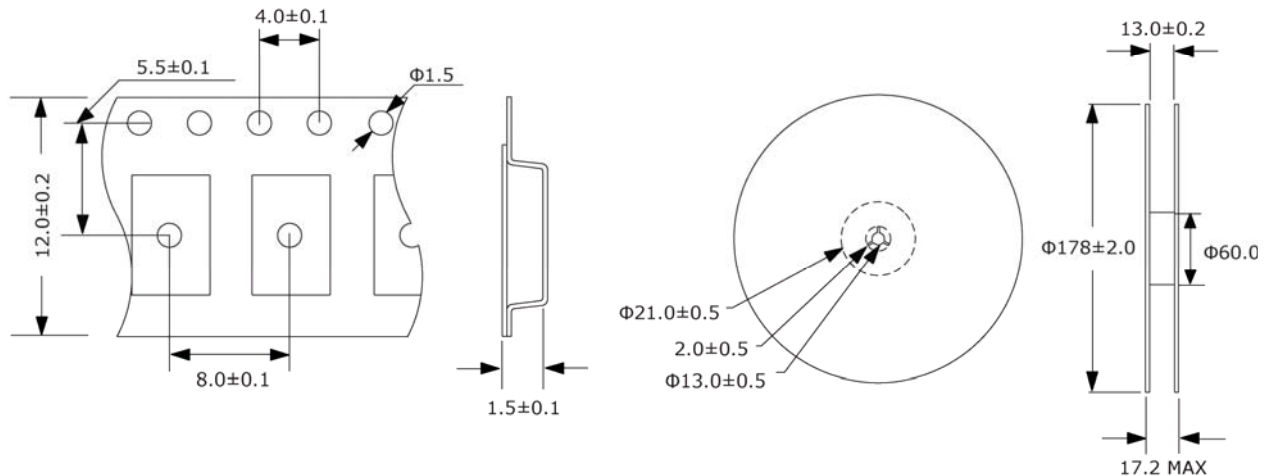

NOTE: Dimensions in millimeters (mm); drawing is not to scale.