



10 mm x 14 mm, FR-4 SMD VCXO, LVPECL / LVDS



I616 Series

Product Features:

- Small Surface Mount Package
- Frequencies to 750 Mhz
- Pb Free/ RoHS Compliant
- Compatible with Leadfree Processing

Applications:

- SD/HD Video
- Wireless Base Stations
- Sonet /SDH
- Server and Storage

Frequency	180 MHz to 750.000 MHz
Output Level LVDS LVPECL	Vod = 393 mV Typ., 475 mV Max. '0' = Vcc - 1.63 V Max. '1' = Vcc - 1.02 V Min.
Duty Cycle	50% ±10%
Rise / Fall Time	0.6 nS Max.
Output Load LVDS LVPECL	100 Ω Differential 50 Ω to Vcc - 2.0 VDC
Frequency Stability	50 ppm Max.
Start-up Time	10 mS Max.
Supply Voltage	3.3 VDC ± 5%
Current	LVDS = 90 mA Max., LVPECL = 130 mA Max.
Linearity	15% Max.
Pullability	See Table Below
Control Voltage	1.65 VDC ± 1.5 VDC
Input Impedance	50K Ω Min.
Operating	See Operating Temperature Table in Part Number Guide
Storage	-55° C to +125° C

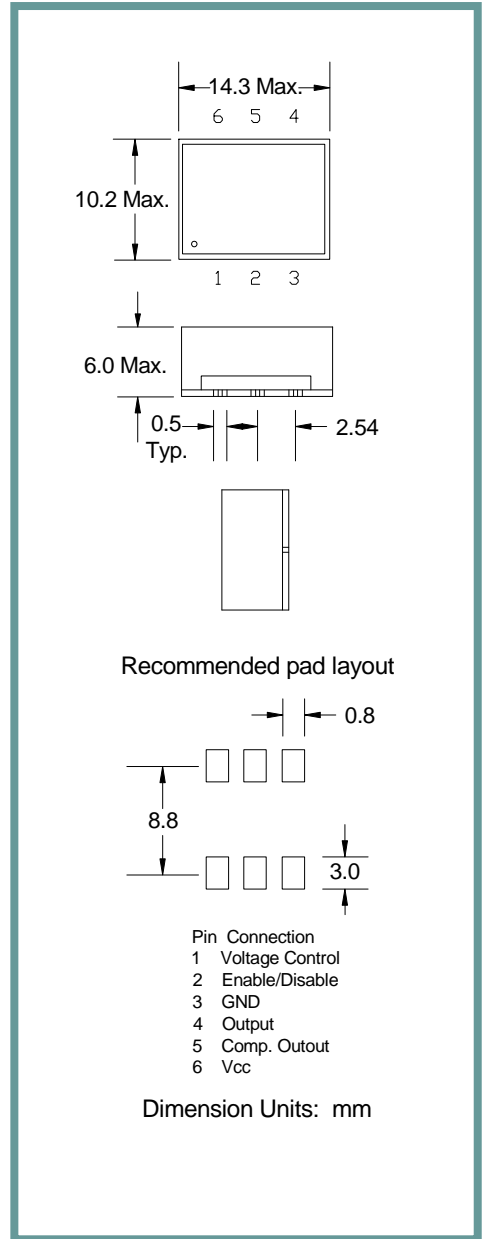

Part Number Guide		Sample Part Number: I616-1BC8H-180.000				
Package	Operating Temperature	Stability (in ppm)	Pullability	Output	Enable / Disable	Frequency
I616	1 = 0° C to +70° C	**D = ±15	B = ±50 ppm	8 = LVDS	H = Enable	-180.000 MHz
	3 = -20° C to +70° C	A = ±25	C = ±100 ppm	9 = LVPECL		
	2 = -40° C to +85° C	B = ±50				
		C = ±100				

NOTE: A 0.01 µF bypass capacitor is recommended between Vcc (pin 6) and GND (pin 3) to minimize power supply noise.

** Not available for all temperature ranges.



10 mm x 14 mm, FR-4 SMD VCXO, LVPECL / LVDS



I616 Series

Pb Free Solder Reflow Profile:

Typical Application:

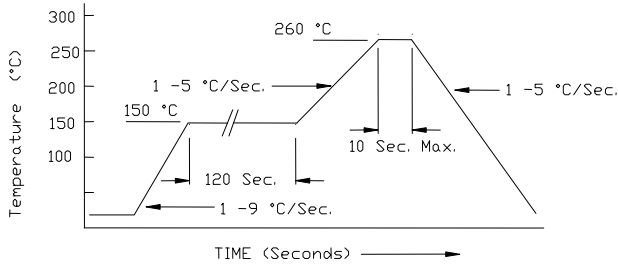

*Units are backward compatible with 240C reflow processes

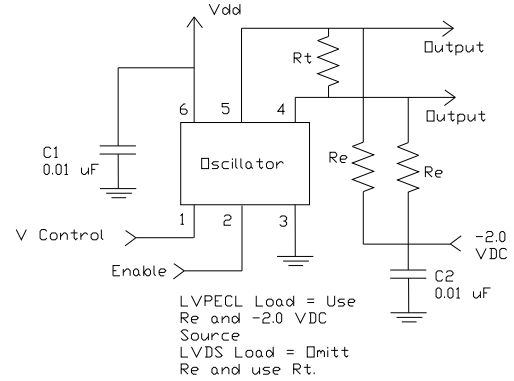

Package Information:

MSL = N.A. (package does not contain plastic, storage life is unlimited under normal room conditions).
 Termination = e4 (Au over Ni over W base metalization).

Tape and Reel Information:

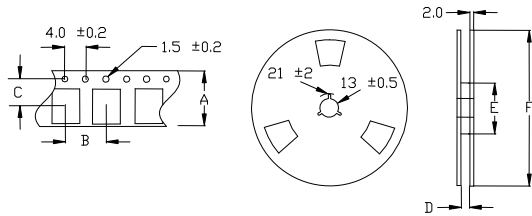

Quantity per Reel	1000
A	16 +/- .3
B	8 +/- .2
C	7.5 +/- .2
D	17.5 +/- .1
E	50 / 60 / 80
F	180 / 250

Environmental Specifications

Thermal Shock	MIL-STD-883, Method 1011, Condition A
Moisture Resistance	MIL-STD-883, Method 1004
Mechanical Shock	MIL-STD-883, Method 2002, Condition B
Mechanical Vibration	MIL-STD-883, Method 2007, Condition A
Resistance to Soldering Heat	J-STD-020C, Table 5-2 Pb-free devices (except 2 cycles max)
Hazardous Substance	Pb-Free / RoHS / Green Compliant
Solderability	JESD22-B102-D Method 2 (Preconditioning E)
Terminal Strength	MIL-STD-883, Method 2004, Test Condition D
Gross Leak	MIL-STD-883, Method 1014, Condition C
Fine Leak	MIL-STD-883, Method 1014, Condition A2, R1=2x10 ⁻⁸ atm cc/s
Solvent Resistance	MIL-STD-202, Method 215

Marking

Line 1: ILSI and Date Code (YWW)
 Line 2: XXXXX (I616-XXXXX- Freq)
 Line 3: Frequency