



2.0 x 1.6 x 0.50 mm

Pb RoHS/RoHS II Compliant

MSL = N/A: NOT APPLICABLE (See Note #1)

ABM11-140-26.000MHz

FEATURES

- Optimized for low power consumption, wearables, and IoT applications
- Guaranteed low 40Ω ESR ensures operation in power sensitive solutions
- 0.50mm max height ideally suited for height constrained designs
- Seam sealed for long-term reliability

APPLICATIONS

- Wearables
- Internet of Things (IoT)
- Bluetooth/Bluetooth Low Energy (BLE)
- Wireless modules
- Machine-to-machine (M2M) connectivity
- Ultra-low power MCU/modules
- WiFi

STANDARD SPECIFICATIONS

PARAMETERS	MINIMUM	TYPICAL	MAXIMUM	UNITS	NOTES
Frequency	26.000			MHz	
Operation Mode	Fundamental				
Operating Temperature	-20		+70	°C	
Storage Temperature	-40		+125	°C	
Frequency Tolerance @+25°C	-10		+10	ppm	See Note#2
Frequency Stability over the Operating Temperature (ref. to +25°C)	-10		+10	ppm	See Note#3
Equivalent series resistance (R1)			40	Ω	
Shunt capacitance (C0)			2	pF	
Load capacitance (CL)	8			pF	
Drive Level		10	100	μW	
Aging@25°C±3°C			±3	ppm	First year
Insulation Resistance	500			MΩ	@ 100Vdc ± 15V

Note#1: Moisture Sensitivity Level (MSL) – This product is Hermetically Sealed and not Moisture Sensitive

Note#2: Referenced to crystal resonant frequency, into an oscillator loop effective load of 8pF

Note#3: Referenced to the measured frequency at 25°C±3°C, into an oscillator loop effective load of 8pF



2.0 x 1.6 x 0.50 mm

Pb RoHS/RoHS II Compliant

MSL = N/A: NOT APPLICABLE (See Note #1)

ABM11-140-26.000MHz

PART IDENTIFICATION AND ORDERING INFORMATION

ABM11-140-26.000MHz-



PACKAGING
Blank: Bulk
T3: 3K/Reel

MECHANICAL DIMENSIONS (ALL DIMENSIONS ARE IN mm)

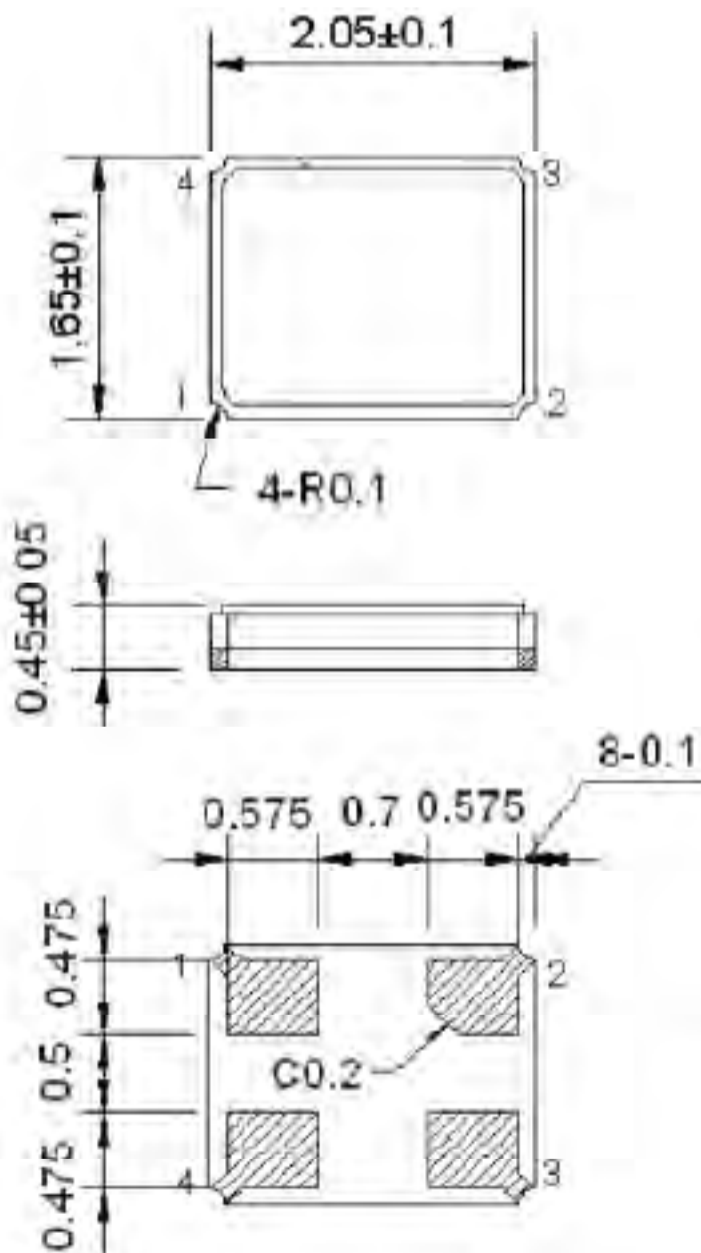

RECOMMENDED LAND PATTERN

<Top View>

