

● FEATURES

- WIDE FREQUENCY RANGE TO 155.520 MHz
- ENABLE/DISABLE AND VOLTAGE CONTROL OPTIONS
- TTL, HCMOS, ACOS, SINEWAVE, CLIPPED SINEWAVE, LVPECL, AND PECL

● SPECIFICATIONS

FREQUENCY RANGE	1.00 TO 155.520 MHz
FREQUENCY STABILITY OVER OPERATING TEMPERATURE (SEE NOTE 1)	LZ-1: ± 1.0 PPM OVER 0° C TO 70° C HZ-1: ± 1.0 PPM OVER -20° C TO 70° C F1-1.5: ± 1.5 PPM OVER -30° C TO 75° C D3-2: ± 2.0 PPM OVER -40° C TO 85° C
FREQUENCY STABILITY VS. CALIBRATION	± 1.0 PPM MAXIMUM
FREQUENCY STABILITY VS. AGING	± 1.0 PPM MAXIMUM PER YEAR
STORAGE TEMPERATURE RANGE	-50° C TO 90° C
OUTPUT WAVEFORM	SEE TABLE 1 FOR OUTPUT TYPES
LOAD	SEE TABLE 1 FOR LOAD CHARACTERISTICS
FREQUENCY STABILITY VS. LOAD VARIATION	± 0.3 PPM MAXIMUM FOR $\pm 10\%$ VARIATION FROM STANDARD LOAD
SUPPLY VOLTAGE	+5.0 VDC $\pm 5\%$, +3.3 VDC $\pm 5\%$ (OPTIONAL)
FREQUENCY STABILITY VS. SUPPLY VARIATION	± 0.3 PPM MAXIMUM FOR $\pm 5\%$ VARIATION FROM NOMINAL SUPPLY
SUPPLY CURRENT	SEE TABLE 1 FOR CURRENT CHARACTERISTICS
ENABLE/DISABLE FUNCTION (TE OPTION)	SEE TABLES 2 AND 3 FOR PIN FUNCTION AND VOLTAGE
VOLTAGE CONTROL FUNCTION (TV OPTION)	SEE TABLE 4 FOR CHARACTERISTICS
ENVIRONMENTAL CONDITIONS	SEE TABLE 5



NOTE 1: OTHER STABILITY OPTIONS AVAILABLE PLEASE CONSULT FACTORY

● OUTPUT WAVEFORM AND LOAD CHARACTERISTICS

TABLE 1 - OUTPUT WAVEFORM AND CHARACTERISTICS, FREQUENCY RANGE, AND MODE OF OSCILLATION				
OUTPUT WAVEFORM	OUTPUT CODE	FREQUENCY RANGE	MODE OF OSCILLATION CODE	OUTPUT CHARACTERISTICS
CLIPPED SINEWAVE	0	8.00 MHz TO 40.00 MHz	F: FUNDAMENTAL	LOAD: 10 K OHM // 10pF OUTPUT LEVEL: 0.7 V P-P MINIMUM SYMMETRY: 60/40 % TO 40/60 % TYPICAL
TTL	1	1.00 MHz TO 40.00 MHz 40.00 MHz TO 100.00 MHz	F: FUNDAMENTAL O: OVERTONE	LOAD: HCMOS TO DRIVE 2 LS TTL NOMINAL OR 10 LS TTL MAXIMUM GATES "1" LEVEL: +2.4 VDC MINIMUM "0" LEVEL: +0.1 VCC MAXIMUM SYMMETRY: 40/60 TO 60/40% AT 1.2 V RISE AND FALL TIME: 10 ns MAXIMUM CURRENT: 20 mA MAXIMUM (F), 30 mA MAXIMUM (O), 45 mA MAXIMUM (PLL)
HCMOS	2	1.00 MHz TO 40.00 MHz 40.00 MHz TO 100.00 MHz	F: FUNDAMENTAL O: OVERTONE	LOAD: 2 LS TTL/HCMOS NOMINAL OR 10 LS TTL/HCMOS MAXIMUM GATES "1" LEVEL: +4.5 VDC MINIMUM "0" LEVEL: +0.5 VDC MAXIMUM SYMMETRY: 40/60 TO 60/40% AT 50% VCC LEVEL RISE AND FALL TIME: 10 ns MAXIMUM JITTER: 10 ps PEAK TO PEAK MAXIMUM CURRENT: 20 mA MAXIMUM (F), 30 mA MAXIMUM (O), 45 mA MAXIMUM (PLL)
ACMOS	3	1.00 MHz TO 40.00 MHz 40.00 MHz TO 100.00 MHz	F: FUNDAMENTAL O: OVERTONE	LOAD: 2 LS TTL/ACMOS NOMINAL OR 10 LS TTL/ACMOS MAXIMUM GATES "1" LEVEL: +4.5 VDC MINIMUM "0" LEVEL: +0.5 VDC MAXIMUM SYMMETRY: 40/60 TO 60/40% AT 50% VCC LEVEL RISE AND FALL TIME: 10 ns MAXIMUM JITTER: 10 ps PEAK TO PEAK MAXIMUM CURRENT: 20 mA MAXIMUM (F), 30 mA MAXIMUM (O), 45 mA MAXIMUM (PLL)
SINEWAVE	6	8.00 MHz TO 40.00 MHz	F: FUNDAMENTAL	LOAD: 50 OHMS NOMINAL OUTPUT LEVEL: 0 dBm MINIMUM HARMONICS: -25 dBc MAXIMUM SPURIOUS: -60 dBc MAXIMUM CURRENT: 20 mA MAXIMUM
PECL	8	100.00 MHz TO 155.520 MHz	O: OVERTONE	LOAD: 50 OHMS CONNECTED TO +3.0 VDC "1" LEVEL: +3.975 VDC MINIMUM "0" LEVEL: +3.38 VDC MAXIMUM SYMMETRY: 40/60 TO 60/40% AT +3.65 VDC LEVEL RISE AND FALL TIME: 5 ns MAXIMUM JITTER: 10 ps PEAK TO PEAK MAXIMUM CURRENT: 130 mA MAXIMUM
LVECL	9	100.00 MHz TO 155.520 MHz	O: OVERTONE	LOAD: 50 OHMS CONNECTED TO +3.0 VDC "1" LEVEL: +3.975 VDC MINIMUM "0" LEVEL: +3.38 VDC MAXIMUM SYMMETRY: 40/60 TO 60/40% AT +3.65 VDC LEVEL RISE AND FALL TIME: 5 ns MAXIMUM JITTER: 10 ps PEAK TO PEAK MAXIMUM CURRENT: 130 mA MAXIMUM

● OUTLINE DRAWING

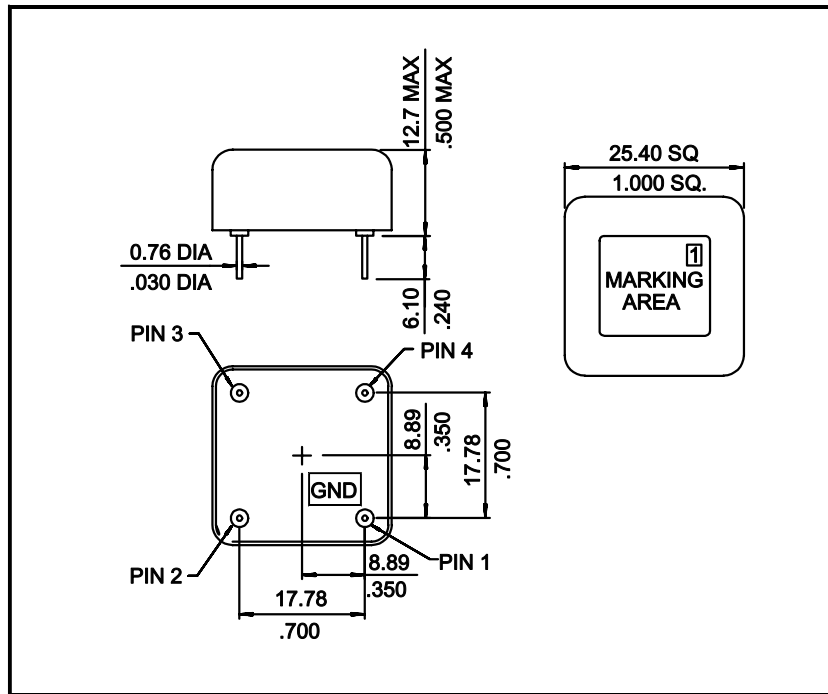

● PIN FUNCTION

	TX	TE	TV
PIN 1	CASE/GROUND	CASE/GROUND	CASE/GROUND
PIN 2	NO CONNECT	ENABLE/DISABLE	V CONT
PIN 3	OUTPUT	OUTPUT	OUTPUT
PIN 4	VCC	VCC	VCC

● ENABLE/DISABLE FUNCTION

ENABLE	+2.0 VDC MINIMUM OR NO CONNECT
DISABLE	+0.4 VDC MAXIMUM

● VOLTAGE CONTROL FUNCTION

CONTROL VOLTAGE RANGE	+0.5 TO +4.5 VDC (0 TO +3.3 VDC)
NOMINAL CONTROL VOLTAGE	+2.5 VDC (1.65 V AT V _{CC} = 3.3 V)
FREQUENCY DEVIATION	±5 PPM MINIMUM
LINEARITY	10% MAXIMUM MONOTONIC
MODULATION BANDWIDTH	10 KHz MINIMUM FOR -3 dBc POINT
INPUT IMPERDANCE	10 K OHMS MINIMUM
SLOPE	POSITIVE

● ENVIRONMENTAL CONDITIONS

MECHANICAL SHOCK	MIL-STD-202F, TEST CONDITION 213, CONDITION A
RANDOM VIBRATION	MIL-STD-202F, TEST CONDITION 214, CONDITION A
SINUSOIDAL VIBRATION	MIL-STD-202F, TEST CONDITION 204, CONDITION A
HERMETICITY	<5 x 10 ⁻⁸ cc ATM/s
SOLDERABILITY	260° C FOR 10 s MAXIMUM