



## VHA6 Series 3.3V VCXO CMOS Oscillator

July 2015



- Pletronics' VHA6 Series is a voltage controlled crystal oscillator with a CMOS output.
- This model uses fundamental mode crystals with no multiplication circuits.
- Tape and Reel or tube packaging is available.
- 1.7 to 108 MHz
- 5x7 mm Ceramic LCC Package
- Voltage Control Function on pad 1
- Enable/ Disable Function on pad 2

**Pletronics Inc. certifies this device is in accordance with the  
RoHS 6/6 (2011/65/EC) and WEEE (2002/96/EC) directives.**

Pletronics Inc. guarantees the device does not contain the following:  
Cadmium, Hexavalent Chromium, Lead, Mercury, PBB's, PBDE's  
Weight of the Device: 0.2 grams  
Moisture Sensitivity Level: 1 As defined in J-STD-020C  
Second Level Interconnect code: e4

### Absolute Maximum Ratings:

Parameter	Unit
V <sub>CC</sub> Supply Voltage	-0.5V to +5.5V
V <sub>i</sub> Input Voltage	-0.5V to V <sub>CC</sub> + 0.5V
V <sub>o</sub> Output Voltage	-0.5V to V <sub>CC</sub> + 0.5V

### Thermal Characteristics

The maximum die or junction temperature is 155°C  
The thermal resistance junction to board is 60 to 100°C/Watt depending on the solder pads, ground plane and construction of the PCB.



# VHA6 Series 3.3V VCXO CMOS Oscillator

July 2015

## Part Number:

VHA6029036	E	G	500	100	-16.384M	-XX	
							Internal code or blank
							<b>Nominal Frequency in MHz</b>
							<b>Pullability in ppm (Vcontrol)</b> (value in ppm) 050 = $\pm 50$ ppm minimum 100 = $\pm 100$ ppm minimum (typical values shown)
							<b>Stability in ppm</b> (Stability in ppm * 10) 000 = APR                      500 = $\pm 50$ ppm 250 = $\pm 25$ ppm                      (typical values shown)
							<b>Highest Specified Operating Temperature</b> A = +40°C    F = +65°C    L = +90°C B = +45°C    G = +70°C    M = +95°C C = +50°C    H = +75°C    N = +100°C D = +55°C    J = +80°C    P = +105°C E = +60°C    K = +85°C
							<b>Lowest Specified Operating Temperature</b> A = +10°C    E = -10°C    J = -30°C B = +5°C    F = -15°C    K = -35°C C = +0°C    G = -20°C    L = -40°C D = -5°C    H = -25°C    M = -45°C
							<b>Series (Part Type, Logic &amp; Package)</b>

## Part Marking:

PLE VHA6                      or                      VHYWWXX  
FF.FFFM                      FF.FFFM  
• YMDXX                      • PXXXXX

### Legend:

P or PLE                      = Pletronics  
FF.FFFM                      = Frequency in MHz  
YWW or YMD                      = Date of Manufacture (year and week, or year, month and day)

All other marking is internal factory codes

Specifications such as frequency stability, supply voltage and operating temperature range, etc. are not identified from the marking. External packaging labels and packing list will correctly identify the ordered Pletronics part number.

### Codes for Date Code YMD

Code	0	1	2	3	4	5	6
Year	2010	2011	2012	2013	2014	2015	2016

Code	A	B	C	D	E	F	G	H	J	K	L	M
Month	JAN	FEB	MAR	APR	MAY	JUN	JUL	AUG	SEP	OCT	NOV	DEC

Code	1	2	3	4	5	6	7	8	9	A	B	C
Day	1	2	3	4	5	6	7	8	9	10	11	12
Code	D	E	F	G	H	J	K	L	M	N	P	R
Day	13	14	15	16	17	18	19	20	21	22	23	24
Code	T	U	V	W	X	Y	Z					
Day	25	26	27	28	29	30	31					

## Electrical Specification for 3.30V $\pm 10\%$ over the specified temperature range

Item	Min	Typ	Max	Unit	Condition	
Frequency Range	1.7	-	108	MHz		
Frequency Accuracy <sup>1</sup>	$\pm 25$	-	-	ppm	Not specified if APR is specified	
Pullability <sup>1</sup>	25-55 MHz	$\pm 90$	-	$\pm 125$	ppm	For Vcontrol 1.65 V $\pm 1.65$ V. Not specified if APR is specified Defined by the part number
	1.7-25 MHz	$\pm 110$	-	$\pm 140$	ppm	
Pullability <sup>1</sup>	25-55 MHz	$\pm 50$	-	-	ppm	Absolute Pull Range, includes the effect of temperature stability Defined by the part number
	<b>APR</b> 1.7-25 MHz	$\pm 75$	-	-	ppm	
Output Waveform	CMOS					
Output High Level	90	-	-	%	of V <sub>CC</sub> for I <sub>OH</sub> = +7 mA	
	70	-	-	%	of V <sub>CC</sub> for I <sub>OH</sub> = +14 mA	
Output Low Level	-	-	10	%	of V <sub>CC</sub> for I <sub>OL</sub> = -7 mA	
	-	-	30	%	of V <sub>CC</sub> for I <sub>OL</sub> = -14 mA	
Output T <sub>RISE</sub> and T <sub>FALL</sub>	-	4.0	6.0	nS	10% to 90% of V <sub>CC</sub> , C <sub>LOAD</sub> = 15 pF	
Output Symmetry	45	50	55	%	at 50% point of V <sub>CC</sub> (See load circuit)	
Vcontrol Resistance Pin 1	20	25	-	Kohm		
Modulation Bandwidth	10	20	-	KHz	Vcontrol = 1.65V $\pm 1.65$ V, -3dB	
E/D Internal Pull-up	50	-	-	Kohm	to V <sub>CC</sub>	
V disable	-	-	15	%	of V <sub>CC</sub> applied to pin 1	
V enable	85	-	-	%	of V <sub>CC</sub> applied to pin 1	
Output leakage	V <sub>OUT</sub> = V <sub>CC</sub>	-10	-	+10	uA	Pin 1 low, device disabled
	V <sub>OUT</sub> = 0V	-10	-	+10	uA	
Enable time	-	-	250	nS	Time for output to reach a logic state	
Disable time	-	-	250	nS	Time for output to reach a high Z state	
Start up time	-	1.5	10	mS	Time for output to reach specified frequency	
Supply Current	-	5.0	8.0	mA	C <sub>LOAD</sub> = 15 pF	
Operating Temperature	-45		+105	°C	Defined by part number	
Storage Temperature Range	-55		+125	°C		

Specifications with Pad 2 E/D open circuit

<sup>1</sup>For all supply voltages, load changes, aging for 1 year, shock, vibration and temperatures.

Typical phase noise plot for 5 oscillators at different output frequencies.

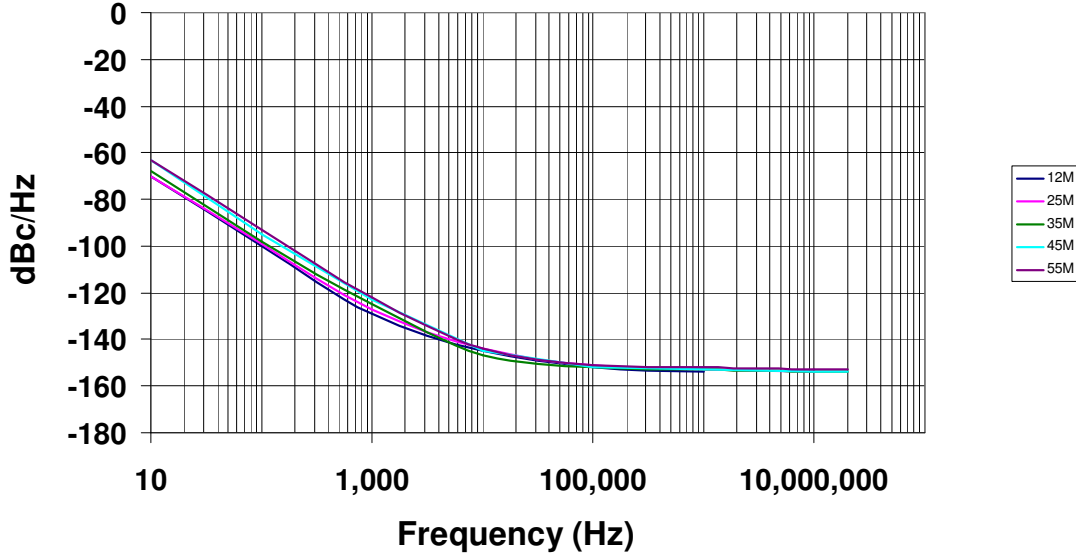

## Load Circuit and Test Waveform

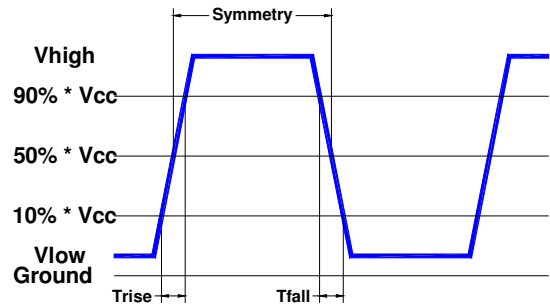
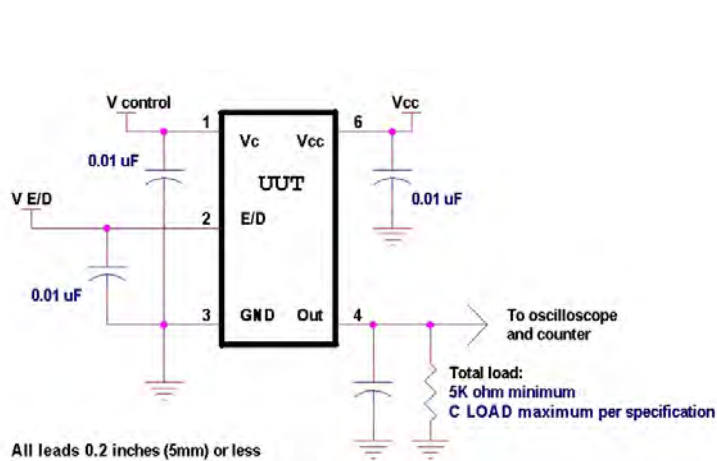

## Reliability: Environmental Compliance

Parameter	Condition
Mechanical Shock	MIL-STD-883 Method 2002, Condition B
Vibration	MIL-STD-883 Method 2007, Condition A
Solderability	MIL-STD-883 Method 2003
Thermal Shock	MIL-STD-883 Method 1011, Condition A



## ESD Rating

Model	Minimum Voltage	Conditions
Human Body Model	1500	MIL-STD-883 Method 3115
Charged Device Model	1000	JESD 22-C101

## Package Labeling

Label is 1" x 2.6" (25.4mm x 66.7mm)  
Font is Courier New  
Bar code is 39-Full ASCII

Label is 1" x 2.6" (25.4mm x 66.7mm)  
Font is Arial

<b>P/N:</b>  VHA6029036EG500100-16.384M
<b>Customer P/N:</b>  12345678
<b>Qty:</b>  1000 <b>D/C</b>  0510M012

<b>RoHS Compliant</b> 2nd LvL Interconnect Category=e4 Max Safe Temp=260C for 10s 2X Max
---

## Mechanical:

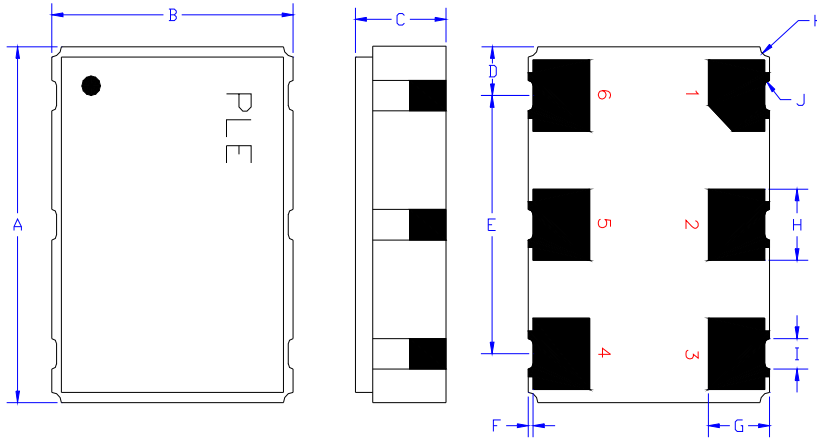

Gold 11.8  $\mu$ mches 0.3  $\mu$ m minimum over  
Nickel 50 to 350  $\mu$ mches 1.27 to 8.89  $\mu$ m

Typical dimensions  
Not to Scale

	Inches	mm
A	0.276 $\pm$ 0.006	7.00 $\pm$ 0.15
B	0.197 $\pm$ 0.006	5.00 $\pm$ 0.15
C	0.073 $\pm$ 0.012	1.87 $\pm$ 0.30
D <sup>1</sup>	0.038	0.96
E <sup>1</sup>	0.200	5.08
F <sup>1</sup>	0.004	0.10
G <sup>1</sup>	0.050	1.27
H <sup>1</sup>	0.055	1.40
I <sup>1</sup>	0.024	0.60
J <sup>1</sup>	0.004R	0.10R
K <sup>1</sup>	0.008R	0.20R

Pad	Function	Note
1	Vcontrol Input	
2	Output Enable/ Disable	When this pad is not connected, the oscillator shall operate When this pad is logic low, the output will be inhibited (high impedance state) Recommend connecting this pad to V <sub>cc</sub> if the oscillator is to be always on
3	Ground (GND)	
4	Output	
5	N.C.	No Internal connection, pad may be connected to ground or V <sub>cc</sub>
6	Supply Voltage (V <sub>cc</sub> )	Recommend connecting appropriate power supply bypass capacitors as close as possible.

## Layout and application information



For Optimum Jitter Performance, Pletronics recommends:

- a ground plane under the device
- no large transient signals (both current and voltage) should be routed under the device do not layout near a large magnetic field such as a high frequency switching power supply
- do not place near piezoelectric buzzers or mechanical fans.

## Reflow Cycle (typical for lead free processing)

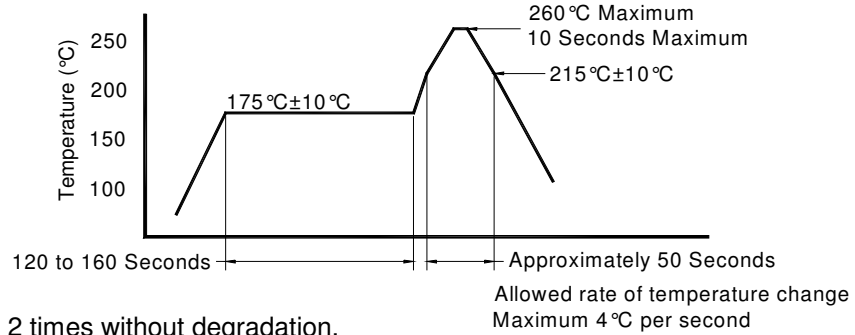

The part may be reflowed 2 times without degradation.

## Tape and Reel: available for quantities of 250 to 1000 per reel

Constant Dimensions Table 1									
Tape Size	D0	D1 Min	E1	P0	P2	S1 Min	T Max	T1 Max	
8mm	1.5	1.0	1.75	4.0	2.0 ± 0.05	0.6	0.6	0.1	
12mm		1.5			2.0 ± 0.1				
16mm		+0.1 -0.0			± 0.1				± 0.1
24mm		1.5			± 0.1				

Variable Dimensions Table 2							
Tape Size	B1 Max	E2 Min	F	P1	T2 Max	W Max	Ao, Bo & Ko
16 mm	12.1	14.25	7.5 ± 0.1	8.0 ± 0.1	8.0	16.3	Note 1

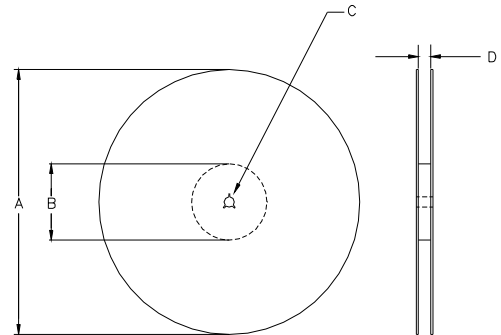

Note 1: Embossed cavity to conform to EIA-481-B      Dimensions in mm      Not to scale

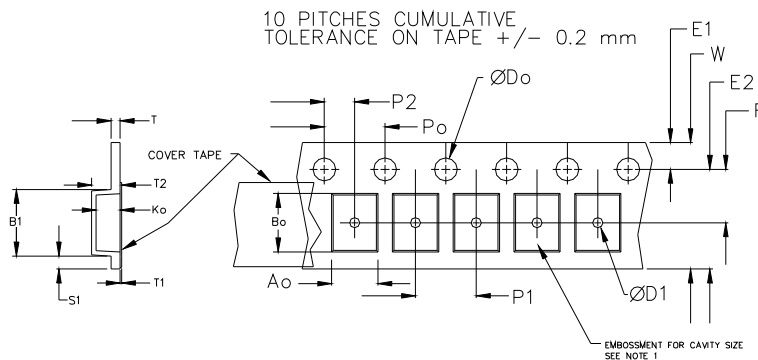

USER DIRECTION OF UNREELING →

REEL DIMENSIONS					
A	inches	7.0	10.0	13.0	Tape Width
	mm	177.8	254.0	330.2	
B	inches	2.50	4.00	3.75	Tape Width
	mm	63.5	101.6	95.3	
C	mm	13.0 +0.5 / -0.2			Tape Width
D	mm	16.4 +2.0 -0.0	16.4 +2.0 -0.0	16.4 +2.0 -0.0	

Reel dimensions may vary from the above