

PE55D Series 2.5 V PECL Clock Oscillators

February 2016

Lead Free 

- Pletronics' PE55D Series is a quartz crystal controlled precision square wave generator with a PECL output.
- The package is designed for high density surface mount designs.
- Low cost mass produced oscillator.
- Tape and Reel or cut tape packaging is available.
- 3.2 x 5 mm LCC Ceramic Package
- Enable/Disable Function on pad 1
- Disable function includes low standby power mode
- 3rd Overtone Crystals used
- Improved circuit to minimize oscillator issues such as multi-mode output signal.
- Low Jitter

**Pletronics Inc. certifies this device is in accordance with the
RoHS 6/6 (2011/65/EC) and WEEE (2002/96/EC) directives.**

Pletronics Inc. guarantees the device does not contain the following:
Cadmium, Hexavalent Chromium, Lead, Mercury, PBB's, PBDE's
Weight of the Device: 0.09 grams
Moisture Sensitivity Level: 1 As defined in J-STD-020D.1
Second Level Interconnect code: e4

Absolute Maximum Ratings:

Parameter	Unit
V _{CC} Supply Voltage	-0.5V to +7.0V
V _i Input Voltage	-0.5V to V _{CC} + 0.5V
V _o Output Voltage	-0.5V to V _{CC} + 0.5V

Thermal Characteristics

The maximum die or junction temperature is 155°C
The thermal resistance junction to board is 45 to 65°C/Watt depending on the solder pads, ground plane and construction of the PCB.

Part Number:

PE55	45	D	E	W	-125.0M	-XX	
							Packaging code or blank T250 = 250 per Tape and Reel T500 = 500 per Tape and Reel T1K = 1000 per Tape and Reel
							Frequency in MHz
							Supply Voltage V_{CC} W = 2.5V \pm 10%
							Optional Enhanced OTR Blank = Temp. range -10 to +70°C C = Temp. range -20 to +70°C E = Temp. range -40 to +85°C
							Series Model
							Frequency Stability 45 = \pm 50 ppm 44 = \pm 25 ppm 20 = \pm 20 ppm
							Series Model

Part Marking:

PFFF.FP
• **YMDX**

Marking Legend:

- P = Pletronics and PECL
- FFF.FF = Frequency in MHz
- YMD = Date of Manufacture (year and week, or year-month-day)
- All other marking is internal factory codes

Specifications such as frequency stability, supply voltage and operating temperature range, etc. are not identified from the marking. External packaging labels and packing list will correctly identify the ordered Pletronics part number.

Codes for Date Code YMD

Code	4	5	6	7	8	Code	A	B	C	D	E	F	G	H	J	K	L	M
Year	2014	2015	2016	2017	2018	Month	JAN	FEB	MAR	APR	MAY	JUN	JUL	AUG	SEP	OCT	NOV	DEC

Code	1	2	3	4	5	6	7	8	9	A	B	C	D	E	F	G
Day	1	2	3	4	5	6	7	8	9	10	11	12	13	14	15	16
Code	H	J	K	L	M	N	P	R	T	U	V	W	X	Y	Z	
Day	17	18	19	20	21	22	23	24	25	26	27	28	29	30	31	

Electrical Specification for 2.50V $\pm 5\%$ over the specified temperature range and the frequency range of 40 to 325 MHz

Item	Min	Max	Unit	Condition	
Frequency Accuracy	"45"	-50	+50	ppm	For all supply voltages, load changes, aging for 1 year, shock, vibration and temperatures
	"44"	-25	+25		
	"20"	-20	+20		
Output Waveform	PECL /ECL				
Output High Level (0°C to 85°C)	1.475	1.760	volts	Referenced to Ground, $V_{CC} = 2.5 V$	
	0.975	1.260	volts	Referenced to termination voltage, $V_{CC} = 2.5 V$	
	-1.025	-0.740	volts	Referenced to V_{CC} , $V_{CC} = 2.5 V$	
Output High Level (-40°C)	1.415	1.620	volts	Referenced to Ground, $V_{CC} = 2.5 V$	
	0.915	1.12	volts	Referenced to termination voltage, $V_{CC} = 2.5 V$	
	-1.085	-0.88	volts	Referenced to V_{CC} , $V_{CC} = 2.5 V$	
Output Low Level (0°C to 85°C)	0.690	1.095	volts	Referenced to Ground, $V_{CC} = 2.5 V$	
	0.190	0.595	volts	Referenced to termination voltage, $V_{CC} = 2.5 V$	
	-1.810	-1.405	volts	Referenced to V_{CC} , $V_{CC} = 2.5 V$	
Output Low Level (-40°C)	0.670	1.195	volts	Referenced to Ground, $V_{CC} = 2.5 V$	
	0.170	0.695	volts	Referenced to termination voltage, $V_{CC} = 2.5 V$	
	-1.830	-1.305	volts	Referenced to V_{CC} , $V_{CC} = 2.5 V$	
Output Symmetry	45	55	%	at 50% point of V_{CC} (See load circuit)	
Jitter ¹	-	0.6	pS RMS	12 KHz to 20 MHz from the output frequency	
	-	2.8	pS RMS	10 Hz to 1 MHz from the output frequency	
Output T_{RISE} and T_{FALL}	-	0.7	nS	V_{th} is 20% and 80% of waveform	
V_{CC} Supply Current (I_{CC})	-	90	mA		
Enable/Disable Internal Pull-up	50	-	Kohm	to V_{CC} , measured with Pad 1 = 0.0 volts	
V disable	-	0.6	volts	Referenced to pad 3	
V enable	1.7	-	volts	Referenced to pad 3	
Output leakage	$V_{OUT} = V_{CC}$	-10	+10	uA	Pad 1 low, device disabled
	$V_{OUT} = 0V$	-10	+10		
Enable time	100	500	nS	Time for output to reach a logic state, the output frequency is correct at the specified Start Time.	
Disable time	-	200	nS	Time for output to reach a high Z state	
Start up time	-	10	mS	Time for output to reach specified frequency	
Operating Temperature Range	-10	+70	°C	Standard Temperature Range	
	-20	+70	°C	Extended Temperature Range "C" Option	
	-40	+85	°C	Extended Temperature Range "E" Option	
Storage Temperature Range	-55	+125	°C		
Standby Current I_{CC}	-	30	uA	Pad 1 low, device disabled	

¹ Jitter computed from phase noise data at 125MHz

Specifications with Pad 1 E/D open circuit unless stated otherwise

Typical Phase-Noise Response

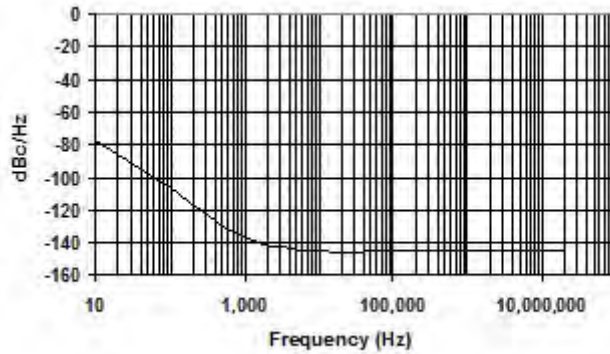

Load Circuit

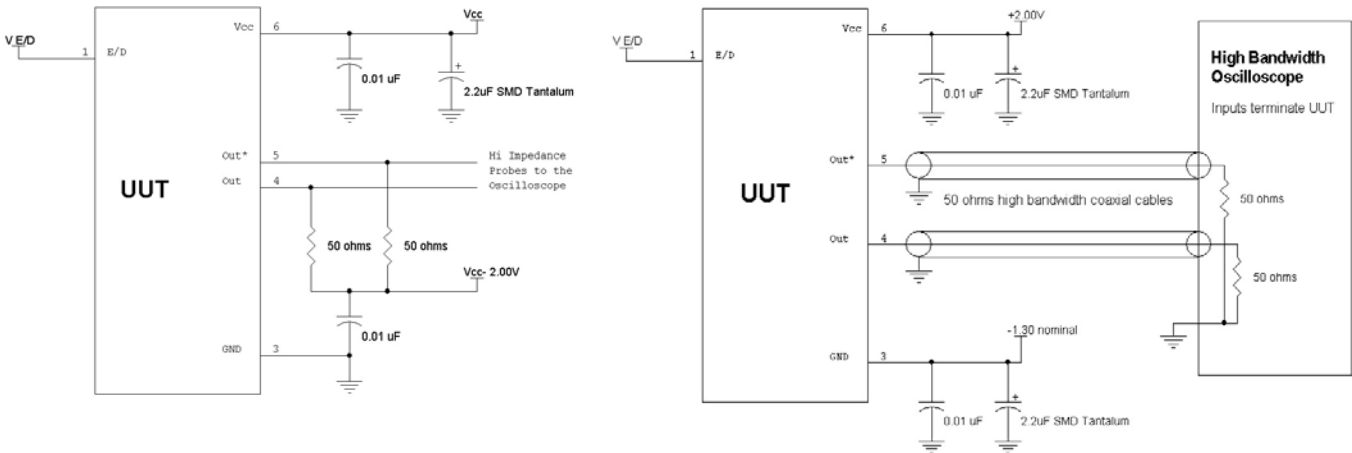

Test Waveform

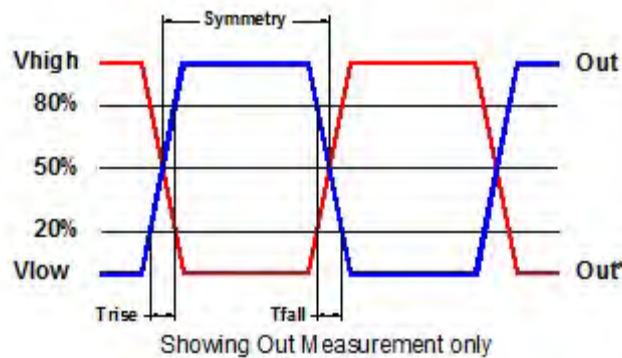

Reliability: Environmental Compliance

Parameter	Condition
Mechanical Shock	MIL-STD-883 Method 2002, Condition B
Vibration	MIL-STD-883 Method 2007, Condition A
Solderability	MIL-STD-883 Method 2003
Thermal Shock	MIL-STD-883 Method 1011, Condition A





ESD Rating

Model	Minimum Voltage	Conditions
Human Body Model	1500	MIL-STD-883 Method 3115
Charged Device Model	1000	JESD 22-C101

Package Labeling

Label is 1" x 2.6" (25.4mm x 66.7mm)
Font is Courier New
Bar code is 39-Full ASCII

Label is 1" x 2.6" (25.4mm x 66.7mm)
Font is Arial

P/N:  PE5545DW-100.0M 
Customer P/N:  12345678
Qty:  1000 D/C  6MC

RoHS Compliant 2nd LvL Interconnect Category=e4 Max Safe Temp=260C for 10s 2X Max

Mechanical:

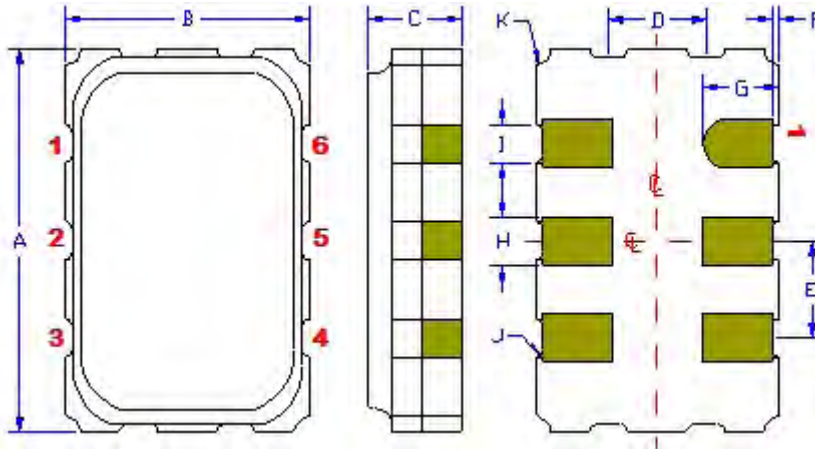

Contacts:

Gold 11.8 to 39.4 microns (0.3 to 1.0 μm)
over
Nickel 50 to 350 microns (1.27 to 8.89 μm)

¹ Typical dimensions

Not to Scale

	Inches	mm
A	0.197 \pm 0.006	5.00 \pm 0.15
B	0.125 \pm 0.006	3.20 \pm 0.15
C	0.053 max	1.35 max
D ¹	0.050	1.27
E ¹	0.050	1.27
F ¹	0.004	0.10
G ¹	0.039	1.00
H ¹	0.025	0.63
I ¹	0.020	0.50
J ¹	0.004R	0.10R
K ¹	0.008R	0.20R

Pad	Function	Note
1	Output Enable/Disable	When this pad is not connected the oscillator shall operate. When this pad is <0.30 volts, the output will be inhibited (high impedance state.) Recommend connecting this pad to V _{CC} if the oscillator is to be always on.
2	No connect	There is no internal connection to this pad
3	Ground (GND)	
4	Output	Both outputs must be terminated and biased for proper operation. The ideal termination is 50 ohms connected to 2.0V below the Supply Voltage.
5	Output*	
6	Supply Voltage (V _{CC})	Recommend connecting appropriate power supply bypass capacitors as close as possible.

Layout and application information

Recommend connecting Pad 1 and Pad 2 together to permit the design to accept Enable/Disable input on either pad

For Optimum Jitter Performance, Pletronics recommends:

- a ground plane under the device
- no large transient signals (both current and voltage) should be routed under the device
- do not layout near a large magnetic field such as a high frequency switching power supply
- do not place near piezoelectric buzzers or mechanical fans.

Reflow Cycle (typical for lead free processing)

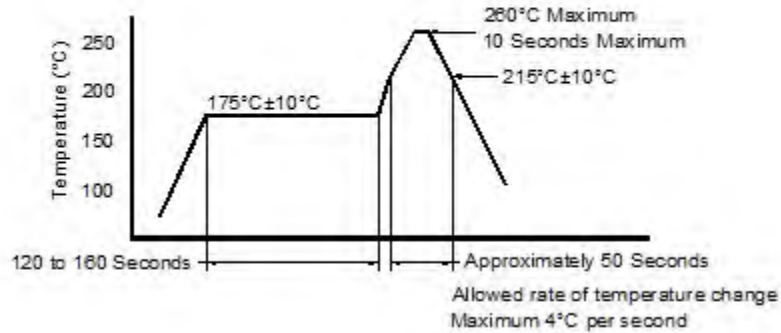

The part may be reflowed 3 times without degradation.

Tape and Reel: available for quantities of 250 to 1000 per reel, cut tape for < 250

Constant Dimensions Table 1								
Tape Size	D0	D1 Min	E1	P0	P2	S1 Min	T Max	T1 Max
8mm	1.5	1.0	1.75	4.0	2.0 ± 0.05	0.6	0.6	0.1
12mm		1.5			2.0 ± 0.1			
16mm		+0.1 -0.0			± 0.1			
24mm		1.5			± 0.1			

Variable Dimensions Table 2							
Tape Size	B1 Max	E2 Min	F	P1	T2 Max	W Max	Ao, Bo & Ko
16 mm	12.1	14.25	7.5 ± 0.1	8.0 ± 0.1	8.0	16.3	Note 1

Note 1: Embossed cavity to conform to EIA-481-B Dimensions in mm Not to scale

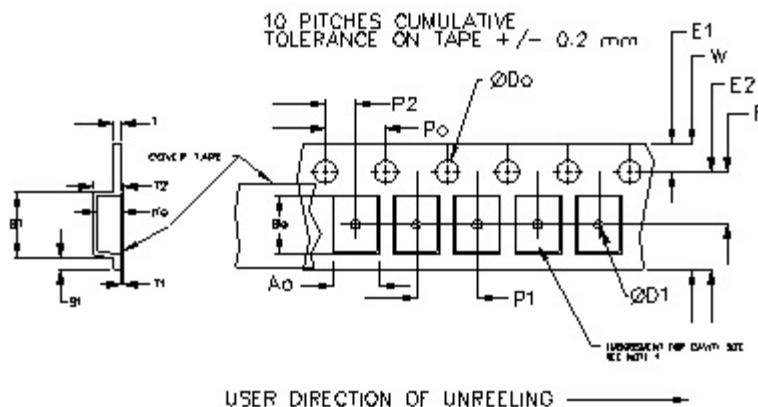
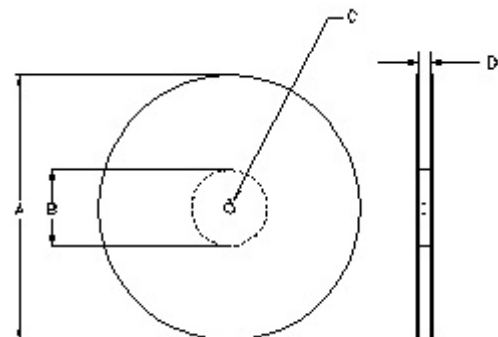

		REEL DIMENSIONS			
A	inches	7.0	10.0	13.0	Tape Width
	mm	177.8	254.0	330.2	
B	inches	2.50	4.00	3.75	Tape Width
	mm	63.5	101.6	95.3	
C	mm	13.0 +0.5 / -0.2			Tape Width
D	mm	16.4 +2.0 -0.0	16.4 +2.0 -0.0	16.4 +2.0 -0.0	

Reel dimensions may vary from the above