



HC55D Series 2.5 V HCSL Clock Oscillators

January 2011



- Pletronics' HC55D Series is a quartz crystal controlled precision square wave generator with a HCSL output.
- The package is designed for high density surface mount designs.
- Low cost mass produced oscillator.
- Tape and Reel or cut tape packaging is available.
- 13 MHz to 220 MHz
- 3.2 x 5 mm LCC Ceramic Package
- Enable/Disable Function on pad 1
- Disable function includes low standby power mode
- Fundamental and 3rd Overtone Crystals used
- Low Jitter

Pletronics Inc. certifies this device is in accordance with the RoHS 6/6 (2002/95/EC) and WEEE (2002/96/EC) directives.

Pletronics Inc. guarantees the device does not contain the following:
 Cadmium, Hexavalent Chromium, Lead, Mercury, PBB's, PBDE's
 Weight of the Device: 0.09 grams
 Moisture Sensitivity Level: 1 As defined in J-STD-020D.1
 Second Level Interconnect code: e4

Absolute Maximum Ratings:

Parameter	Unit
V _{CC} Supply Voltage	-0.5V to +5.0V
V _i Input Voltage	-0.5V to V _{CC} + 0.5V
V _o Output Voltage	-0.5V to V _{CC} + 0.5V

Thermal Characteristics

The maximum die or junction temperature is 155°C
 The thermal resistance junction to board is 30 to 50°C/Watt depending on the solder pads, ground plane and construction of the PCB.

Part Number:

HC55	45	D	E	W	-125.0M	-XX	
							Packaging code or blank T250 = 250 per Tape and Reel T500 = 500 per Tape and Reel T1K = 1000 per Tape and Reel
							Frequency in MHz
							Supply Voltage V_{CC} W = 2.5V ± 10%
							Optional Enhanced OTR Blank = Temp. range -10 to +70°C C = Temp. range -20 to +70°C E = Temp. range -40 to +85°C
							Series Model
							Frequency Stability 45 = ± 50 ppm 44 = ± 25 ppm 20 = ± 20 ppm
							Series Model

Part Marking and Legend:



P = Pletronics
 H = HCSL
 FFF.F = Frequency in MHz
 YMD = Date of Manufacture (year and week, or year-month-day)
 All other marking is internal factory codes

Specifications such as frequency stability, supply voltage and operating temperature range, etc. are not identified from the marking. External packaging labels and packing list will correctly identify the ordered Pletronics part number.

Codes for Date Code YMD

Code	0	1	2	3	4	Code	A	B	C	D	E	F	G	H	J	K	L	M
Year	2010	2011	2012	2013	2014	Month	JAN	FEB	MAR	APR	MAY	JUN	JUL	AUG	SEP	OCT	NOV	DEC

Code	1	2	3	4	5	6	7	8	9	A	B	C	D	E	F	G
Day	1	2	3	4	5	6	7	8	9	10	11	12	13	14	15	16
Code	H	J	K	L	M	N	P	R	T	U	V	W	X	Y	Z	
Day	17	18	19	20	21	22	23	24	25	26	27	28	29	30	31	

Electrical Specification for 2.50V $\pm 10\%$ over the specified temperature

Item	Min	Typ	Max	Unit	Condition	
Frequency Accuracy	"45"	-50	0	50	ppm	For all supply voltages, load changes, aging for 1 year, shock, vibration and temperatures
	"44"	-25	0	25		
	"20"	-20	0	20		
Power Supply Sensitivity	-1	-	1	ppm	For V_{CC} change of $\pm 10\%$	
Output Waveform	HCSL					
Output High Level	660	740	850	mV	See load circuit	
Output Low Level	-	0	150	mV	See load circuit	
Output Symmetry	45	50	55	%	at 50% point of output See load circuit	
Jitter	-	0.2	0.6	pS RMS	12 KHz to 20 MHz from the output frequency	
	-	-	2.8	pS RMS	10 Hz to 1 MHz from the output frequency	
Output T_{RISE} and T_{FALL}	-	0.3	0.5	nS	V_{th} is 20% and 80% of output waveform	See load circuit
V_{CC} Supply Current (I_{CC})	-	18 19 20	28 29 30	mA	<130 MHz ≥130 MHz to 170 MHz >170 MHz	See load circuit
Enable/Disable Internal Pull-up	200	-	-	Kohm	to V_{CC} , measured with Pad 1 = 0.0 volts	
V disable	-	-	0.6	volts	Referenced to pad 3	
V enable	2.40	-	-	volts	Referenced to pad 3	
Output leakage	-10	-	10	uA	Pad 1 low, device disabled	
Enable time	-	-	2	mS	Time for output to reach specified frequency	
Disable time	-	-	200	nS	Time for output to reach a high Z state	
Start up time	-	-	2	mS	Time for output to reach specified frequency	
Operating Temperature Range	-10	-	+70	°C	Standard Temperature Range	
	-20	-	+70	°C	Extended Temperature Range "C" Option	
	-40	-	+85	°C	Extended Temperature Range "E" Option	
Storage Temperature	-55	-	+125	°C		
Standby Current I_{CC}	-	-	20	uA	Pad 1 low, device disabled	

Specifications with Pad 1 E/D open circuit unless stated otherwise

Typical Phase-Noise Response

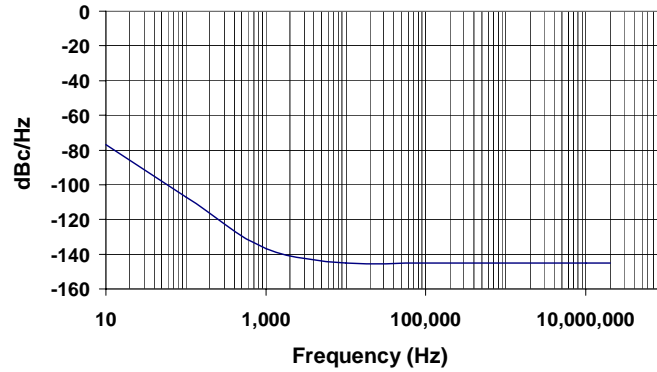

Test and Load Circuit

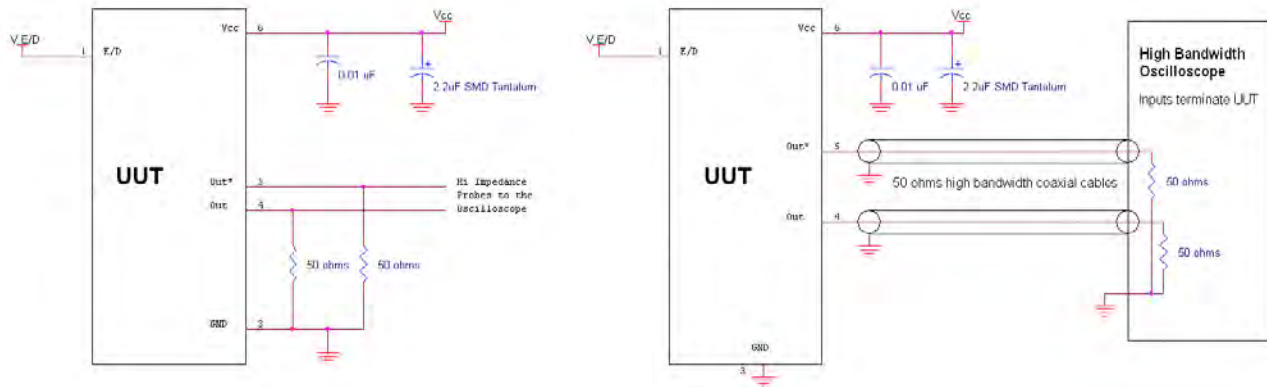

Test Waveform

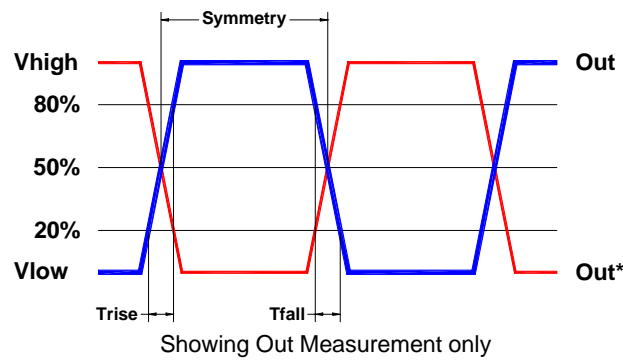

Reliability: Environmental Compliance

Parameter	Condition
Mechanical Shock	MIL-STD-883 Method 2002, Condition B
Vibration	MIL-STD-883 Method 2007, Condition A
Solderability	MIL-STD-883 Method 2003
Thermal Shock	MIL-STD-883 Method 1011, Condition A



ESD Rating

Model	Minimum Voltage	Conditions
Human Body Model	1500	MIL-STD-883 Method 3115
Charged Device Model	1000	JESD 22-C101

Package Labeling

Label is 1" x 2.6" (25.4mm x 66.7mm)
Font is Courier New
Bar code is 39-Full ASCII

Label is 1" x 2.6" (25.4mm x 66.7mm)
Font is Arial

P/N:  HC5545DW-100.0M Customer P/N:  123456 Qty:  1000 D/C  0AZ MSL: 1

RoHS Compliant 2nd Lvl Interconnect Category=e4 Max Safe Temp=260C for 10s 2X Max

Mechanical:

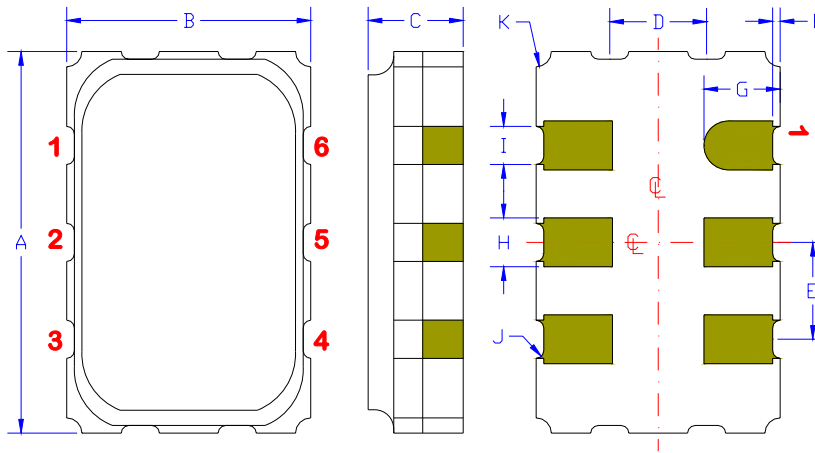

	Inches	mm
A	0.197 ±0.006	5.00 ±0.15
B	0.125 ±0.006	3.20 ±0.15
C	0.053 max	1.35 max
D ¹	0.050	1.27
E ¹	0.050	1.27
F ¹	0.004	0.10
G ¹	0.039	1.00
H ¹	0.025	0.63
I ¹	0.020	0.50
J ¹	0.004R	0.10R
K ¹	0.008R	0.20R

Contacts:

Gold 11.8 to 39.4 μinches (0.3 to 1.0 μm)
over
Nickel 50 to 350 μinches (1.27 to 8.89 μm)

¹ Typical dimensions

Not to Scale

Pad	Function	Note
1	Output Enable/Disable	When this pad is not connected the oscillator shall operate. When this pad is <0.30 volts, the output will be inhibited (high impedance state.) Recommend connecting this pad to V _{CC} if the oscillator is to be always on.
2	No connect	There is no internal connection to this pad
3	Ground (GND)	
4	Output	Both outputs must be terminated and biased for proper operation. The ideal termination is 50 ohms connected to ground.
5	Output*	
6	Supply Voltage (V _{CC})	Recommend connecting appropriate power supply bypass capacitors as close as possible.

Layout and application information

For Optimum Jitter Performance, Pletronics recommends:

- a ground plane under the device
- no large transient signals (both current and voltage) should be routed under the device
- do not layout near a large magnetic field such as a high frequency switching power supply
- do not place near piezoelectric buzzers or mechanical fans.

Reflow Cycle (typical for lead free processing)

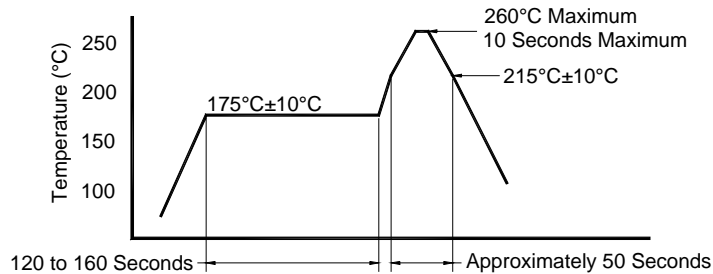

The part may be reflowed 3 times without degradation.

Allowed rate of temperature change
Maximum 4°C per second

Tape and Reel: available for quantities of 250 to 1000 per reel, cut tape for < 250

Constant Dimensions Table 1								
Tape Size	D0	D1 Min	E1	P0	P2	S1 Min	T Max	T1 Max
8mm	1.5	1.0	1.75	4.0	2.0 ±0.05	0.6	0.6	0.1
12mm		1.5			2.0 ±0.1			
16mm	+0.1 -0.0	1.5	±0.1	±0.1	2.0 ±0.1	0.6	0.6	0.1
24mm	-0.0	1.5	±0.1					

Variable Dimensions Table 2							
Tape Size	B1 Max	E2 Min	F	P1	T2 Max	W Max	Ao, Bo & Ko
16 mm	12.1	14.25	7.5 ± 0.1	8.0 ± 0.1	8.0	16.3	Note 1

Note 1: Embossed cavity to conform to EIA-481-B Dimensions in mm Not to scale

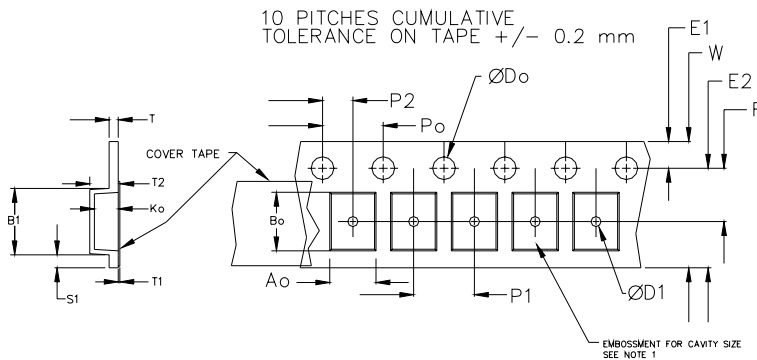
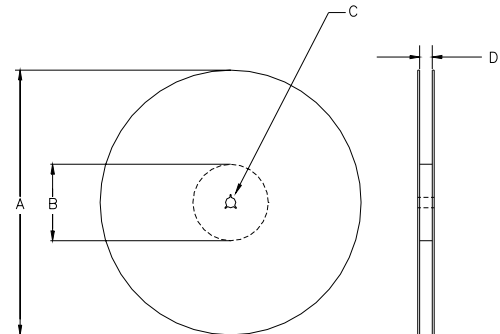

REEL DIMENSIONS					
A	inches	7.0	10.0	13.0	Tape Width
	mm	177.8	254.0	330.2	
B	inches	2.50	4.00	3.75	Tape Width
	mm	63.5	101.6	95.3	
C	mm	13.0 +0.5 / -0.2			Tape Width
D	mm	16.4	16.4	16.4	16.0
		+2.0 -0.0	+2.0 -0.0	+2.0 -0.0	

USER DIRECTION OF UNREELING Reel dimensions may vary from the above