



actual size

Quartz Crystal · MQ5-SMC

UM5-SMD Crystal Version · 9.7 x 7.7 mm

- automotive temperature range available
- reflow soldering temperature: 260 °C max.
- package height 3.6 mm max.



General Data

type	MQ5 (UM5-SMC)
frequency range	10.0 ~ 40.0 MHz (fund. AT-cut)
	30.0 ~ 105.0 MHz (3rd OT AT-cut)
	50.0 ~ 175.0 MHz (5th OT AT-cut)
	70.0 ~ 250.0 MHz (7th OT AT-cut)
frequency tolerance at 25 °C	± 5 ppm ~ ± 30 ppm
load capacitance C_L	8 pF ~ 30 pF or series
shunt capacitance C_0	< 7 pF
storage temperature	-55 °C ~ +125 °C
drive level max.	500 μ W (100 μ W recommended)
aging	< ± 3 ppm first year

Dimensions

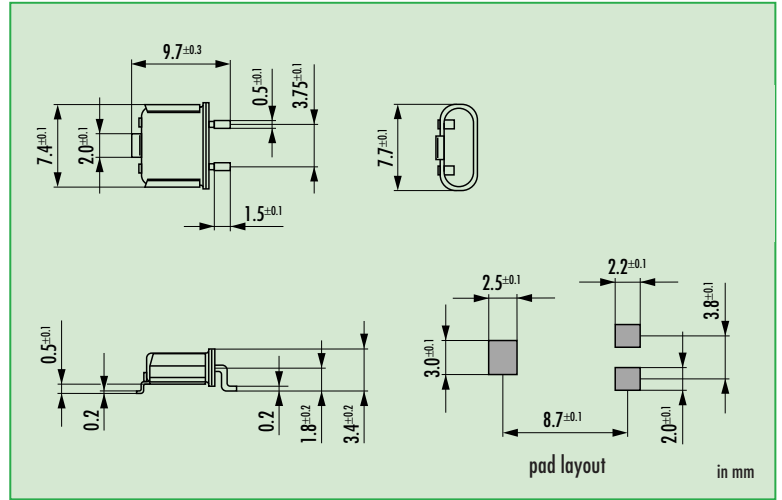

Frequency Stability vs. Temperature

	± 3 ppm	± 5 ppm	± 10 ppm	± 30 ppm	± 50 ppm	± 100 ppm
0 °C ~ +60 °C	○	○	○			
-20 °C ~ +70 °C	STD.	○	○	●		
-40 °C ~ +85 °C	T1		○	○	●	
-40 °C ~ +90 °C	T4			○	○	○
-40 °C ~ +105 °C	T2			○	○	○
-40 °C ~ +125 °C	T3					

● standard
○ available

ESR (series resistance R_s)

frequency in MHz	vibration mode	ESR max. in Ω	ESR typ. in Ω
10.0 ~ 19.999	fund.- AT	60	40
20.0 ~ 40.000	fund.- AT	40	20
30.0 ~ 79.999	3rd OT - AT	100	70
80.0 ~ 105.00	3rd OT - AT	80	50
50.0 ~ 59.999	5th OT - AT	250	200
60.0 ~ 129.99	5th OT - AT	200	160
130.0 ~ 175.0	7th OT - AT	180	150

Order Information

Q	frequency	type	load capacitance in pF	stability at 25 °C	stability vs. temp. range	option	SMD version
Quartz	10.0 ~ 250.0 MHz	MQ5	8 pF ~ 30 pF S for series	± 5 ~ ± 30 ppm	see table	blank = -20 °C ~ + 70 °C T1 = -40 °C ~ + 85 °C T2 = -40 °C ~ +105 °C T3 = -40 °C ~ +125 °C T4 = -40 °C ~ + 90 °C FU = for fundamental frequencies ≥ 20 MHz 3OT = 3rd overtone 5OT = 5th overtone 7OT = 7th overtone	SMC

Example: Q 30.0-MQ5-30-30/50-T1-FU-SMC-LF (Suffix LF = RoHS compliant / Pb free pins or pads)