

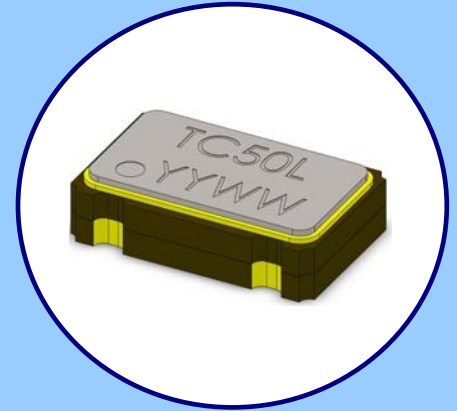

FEATURES

- 32.7680 kHz Frequency Reference
- Package Size 5.0mm x 3.2mm
- Fundamental Crystal Design
- Hermetic Ceramic Package
- Frequency Stability, ± 50 ppm Standard
- Operating Temperature, -40°C to $+85^{\circ}\text{C}$ Standard
- Tape & Reel Packaging, EAI-418
- **RoHS/Green Compliant [6/6]**



APPLICATIONS

Model TC50 is ideal for use in a wide range of communication equipment, measurement equipment, industrial applications, automotive electronics, wireless communications, PDAs, mobile phones and notebooks.

ORDERING INFORMATION

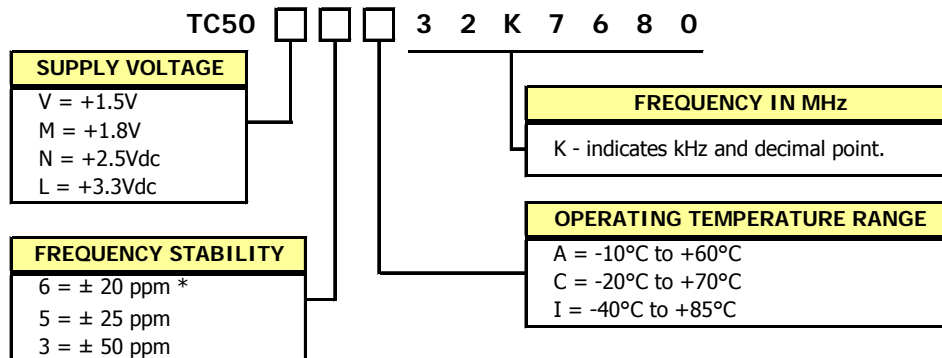

* Temperature codes A and C.

Example Part Numbers:

TC50L3I32K7680

TC50L5I32K7680

**Not all performance combinations and frequencies may be available.
Contact your local CTS Representative or CTS Customer Service for availability.**

PACKAGING INFORMATION [Reference Only]

Device quantity is 1k pcs minimum and 3k pcs. maximum per 180mm reel.
DIMENSIONS IN MILLIMETERS

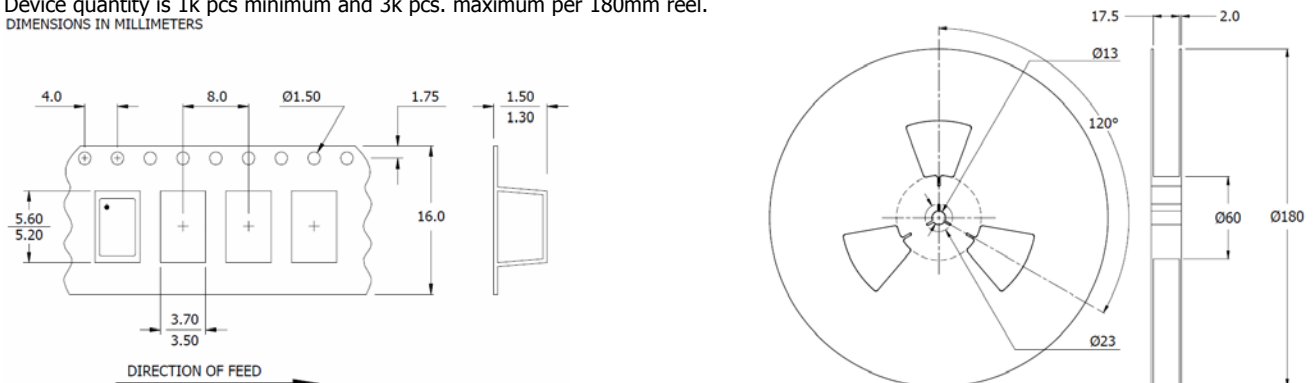

ELECTRICAL CHARACTERISTICS

PARAMETER	SYMBOL	CONDITIONS	MIN	TYP	MAX	UNIT
Frequency	f_o	-		32.7680		kHz
Operating Mode	-	-	AT Fundamental			-
Output Type	-	-	HCMOS			
Supply Voltage	V_{CC}	$\pm 10\%$	1.5, 1.8, 2.5, 3.3			V
Current	I_{CC}	15pF Load	-	-	3.0	mA
Frequency Stability	$\Delta f/f_o$	See Ordering Information	20, 25, 50			ppm
Operating Temperature Range	T_A	-	-10	-	+60	°C
			-20	-	+70	
			-40	-	+85	
Load Capacitance	C_L	CMOS	-	15	-	pF
Output Voltage Levels						
Logic '1' Level	V_{OH}	CMOS Load	$0.9V_{CC}$	-	-	V
Logic '0' Level	V_{OL}	CMOS Load	-	-	$0.1V_{CC}$	
Rise and Fall Time	T_{r}, T_f	-	-	50	200	ns
Output Duty Cycle	SYM	@ 50% Level	45	-	55	%
Start-up Time	T_S	Application of V_{CC}	-	5.0	10	ms
Enable Function						
Enable Input Voltage	V_{IH}	Pin 1 Logic '1', Output Enabled	$0.7V_{CC}$	-	-	V
Disable Input Voltage	V_{IL}	Pin 1 Logic '0', Output Disabled	-	-	$0.3V_{CC}$	
Aging	$\Delta f/f_o$	@ +25°C, 1st year	-	3.0	5.0	\pm ppm
Storage Temperature Range	T_{STR}	-	-55	-	+125	°C

MECHANICAL SPECIFICATIONS

TC50 PACKAGE DRAWING

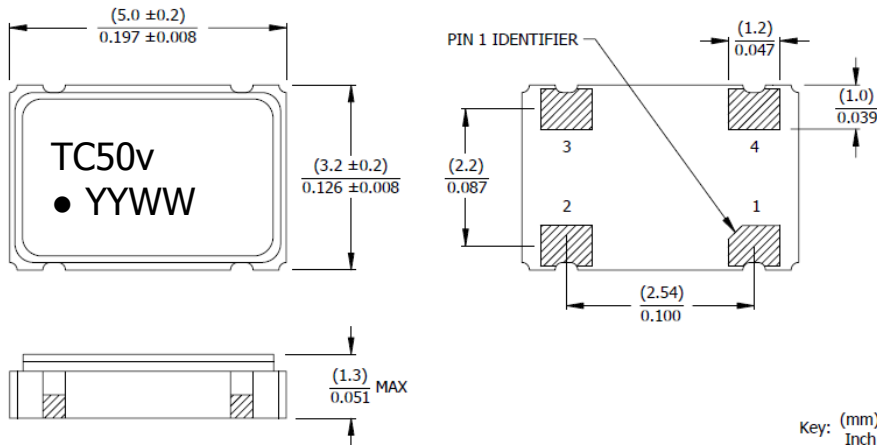

MARKING INFORMATION

- TC50 – CTS Model Series.
- v – Voltage code.
[L=3.3V, N=2.5V, M=1.8V, V=1.5V]
- – Pin 1 identifier.
- YYWW – Date code, YY – year, WW – week.

Complete CTS part number, frequency value, date code and manufacturing site code information must appear on reel and carton labels.

NOTES

- Termination pads (e4); barrier plating is nickel [Ni] with gold [Au] flash plate.
- Reflow conditions per JEDEC J-STD-020; 260°C maximum, 20 seconds.
- MSL = 1.

SUGGESTED SOLDER PAD GEOMETRY

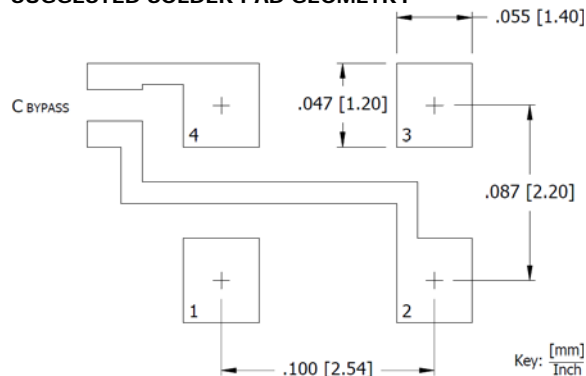

C_{BYPASS} should be $\geq 0.01 \mu F$.

PIN ASSIGNMENTS

PIN	SYMBOL	DESCRIPTION
1	EOH	Enable Input
2	GND	Circuit & Package Ground
3	Output	RF Output
4	V_{CC}	Supply Voltage