

SMD TYPE CERAMIC (SMD 7 x 5)

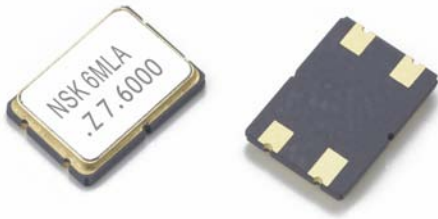

Application of SMD crystal:

- Radio communication
- TCXO
- Office automation equipment
- GPS
- Audio-visual equipment



{ Features }

Seam welding
 Excellent solderability
 Automatic and perfect packing due to emboss taping
 Excellent vibration resistance & shock resistance
 Rohs compliant / Pb free

Electrical Specification:

Model	NXD-75
1.Frequency	
Frequency Range	6.0 ~ 125.000 MHz
Frequency Tolerance at 25 ℃ ± ℃	±0 ~ ±100 ppm (TYP.)
Frequency Stability Over Operating Temp Range	±0 ~ ±100 ppm (TYP.)
2.Environmental Condition	
Operating Temp Range	-10 ℃~ +60 ℃,-20 ℃~ +70 ℃ or customer requirement
Storage Temp Range	-40 ℃ ~ +85 ℃
Aging Rate	±3ppm/year
3.Electrical Specifications	
Test Circuit	S&A 250B
Load Capacitance	6 pF ~ 32 pF, series or special
Drive Level	1uW ~ 100uW or special
Shunt Capacitance	7.0pF max

Equivalent Series Resistance(ESR) VS Frequency:

Frequency (MHz)	Oscillation Mode	NXD-75
6.0 ~ 10.0	Fundamental	110
10.1 ~ 22.0	Fundamental	80
22.1 ~ 40.0	Fundamental	40
40.1 ~ 125.0	3rd overtone	80

Dimensions (mm):

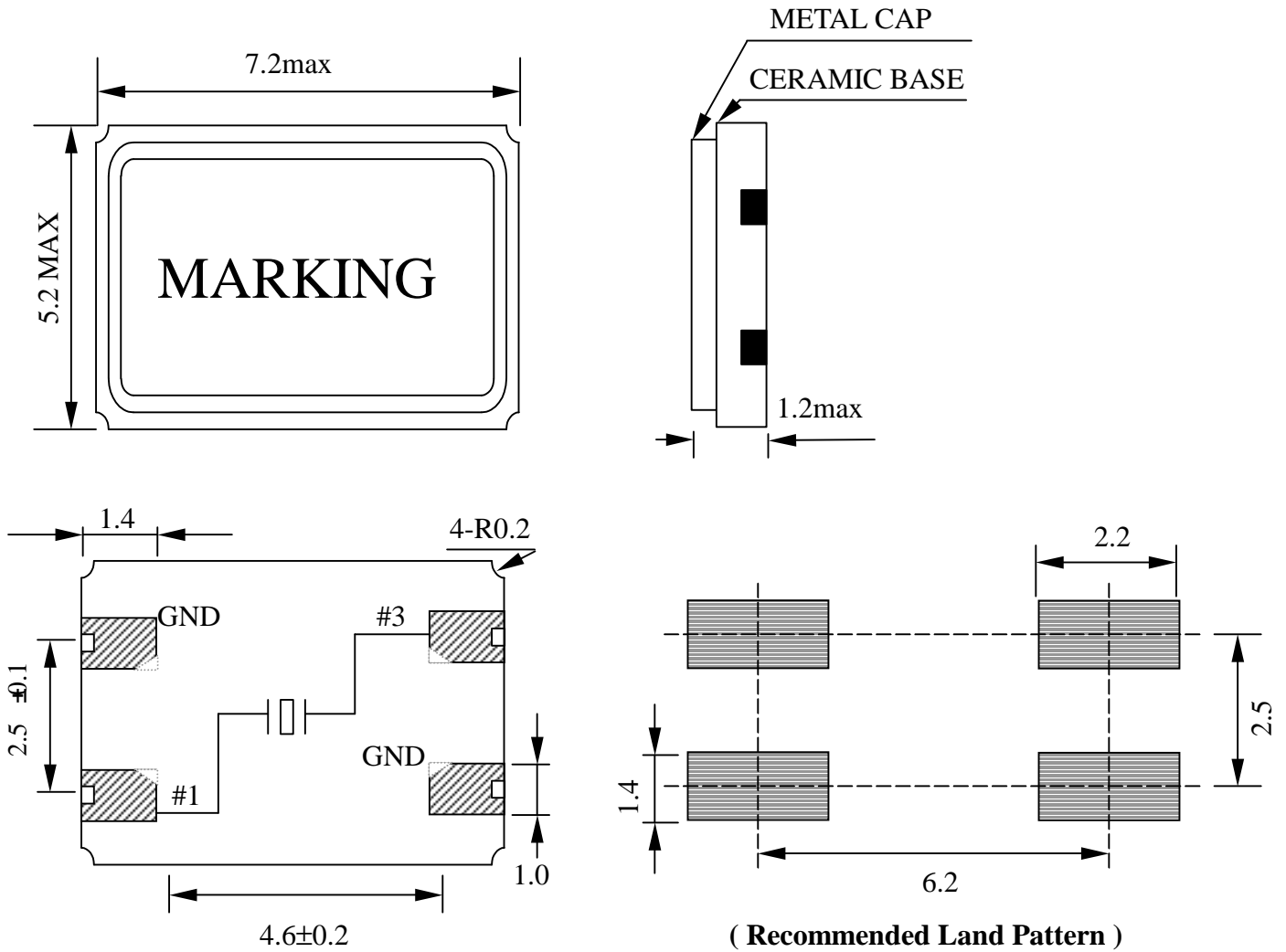

Tape specification: (Unit: mm)

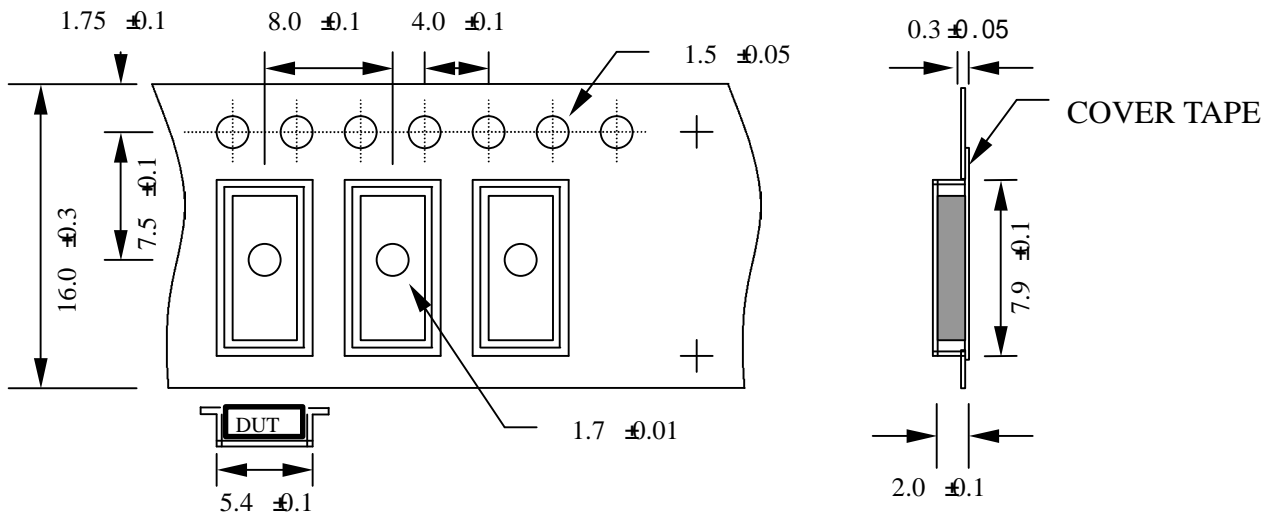

Reel packing: (Unit: mm)

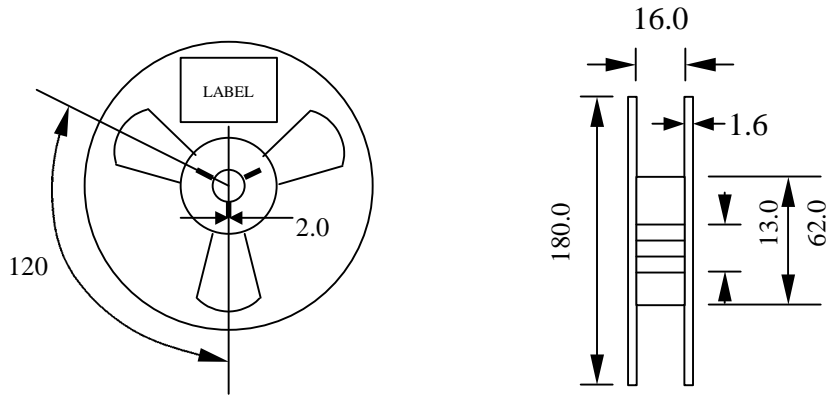

Reflow Temperature profile:

